

Analog Stand alone servodrive 45 - 95 - 150 Vac power supply range for Brush servomotors. Driving motor ranges up to 16 Nm, tacho generator, encoder or armature feedback.

MASTERBOX

SERVO AMPLIFIER FOR BRUSH DC MOTORS

MASTERBOX is a precision four quadrant regenerative servo drive for permanent dc Brush servomotors. Possible control methods include velocity and torque modes. There are many different feedback modes: tachogenerator, encoder, and armature feedback. The converters are equipped with an internal power supply and an integrated 200W braking module.

► Masterbox advantage

- Compact drive for 5KW (16Nm) motors
- Versatility, ease-of-use, cost-effective
- Feedback for motors with tachogenerator, Armature, encoder.

► Standard characteristic

- Four quadrant regenerative operation
- AC power supply 3Ph or 1Ph
- 6 diagnostic Leds (State and Alarms)
- Protections for: Over/Under voltage, max. temperature reaches, Over current, I2t motor current, Pre allarm Braking, Max. Braking module.
- Power and signals extractable connectors
- 1 Differential velocity input +/-10V
- 1 Stop input
- Feedback available (series): - tachogenerator - Armature - Quadrature encoder
- Fault drive output (Relays)
- Five Potentiometer adjustments (Speed, offset, gain, derivative, acceleration/deceleration ramp)



► Specifications

- PWM frequency 20Khz
- Operative temperature 0/+45°C
- Analog inputs range +/-10Vdc
- Current monitor +/- 8Vdc (At pk curr.)
- Encoder power supply (Opt.) +5Vdc @130 mA
- Auxiliary power supply +/-10Vdc @4mA
- Maximum encoder frequency 300Khz
- Logic level encoder inputs ≥ +2,8V/+24V
- Start signal (Input range) +9V/+30Vdc
- Current loop bandwidth 2KHz
- Velocity loop bandwidth 150Hz

MODEL	MASTERBOX 60	MASTERBOX 140	MASTERBOX 200
AC Voltage 3PH (1) (Vac)	45	95	150
AC Voltage Range (Vac)	30 - 50	35 - 110	60 - 160
Size (A)	4/8	8/16	10/20 14/28 20/40 25/50
Rated Current (A)	4	8	10 14 20 25
Peak Current (2) (A)	8	16	20 28 40 50

Order code example:

MTSB - 140 - 14 - T - RD - RX - ord.104/19

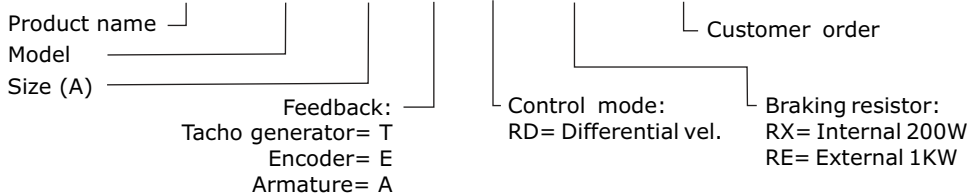

Label example:

**MTSB-140-14-T-RD-RX
ord. 104/19**

(1) AC Nominal voltage (2) Peak current (Adc) for 2 sec. * Current sizes are available for all model MTSB Servodrives. Size 20/40a and 25/50A available in MAXI version.

► Mechanical dimensions

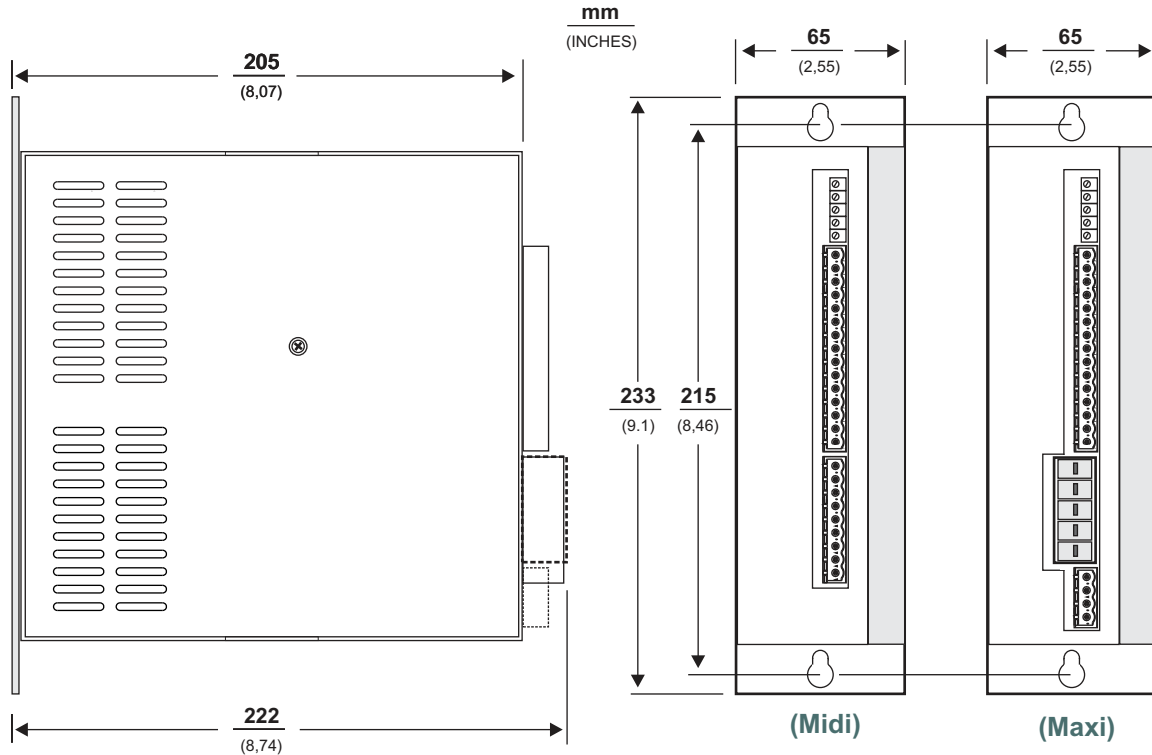

[Datasheet MasterBox (gb) - 2 of 2]

► Typical connection

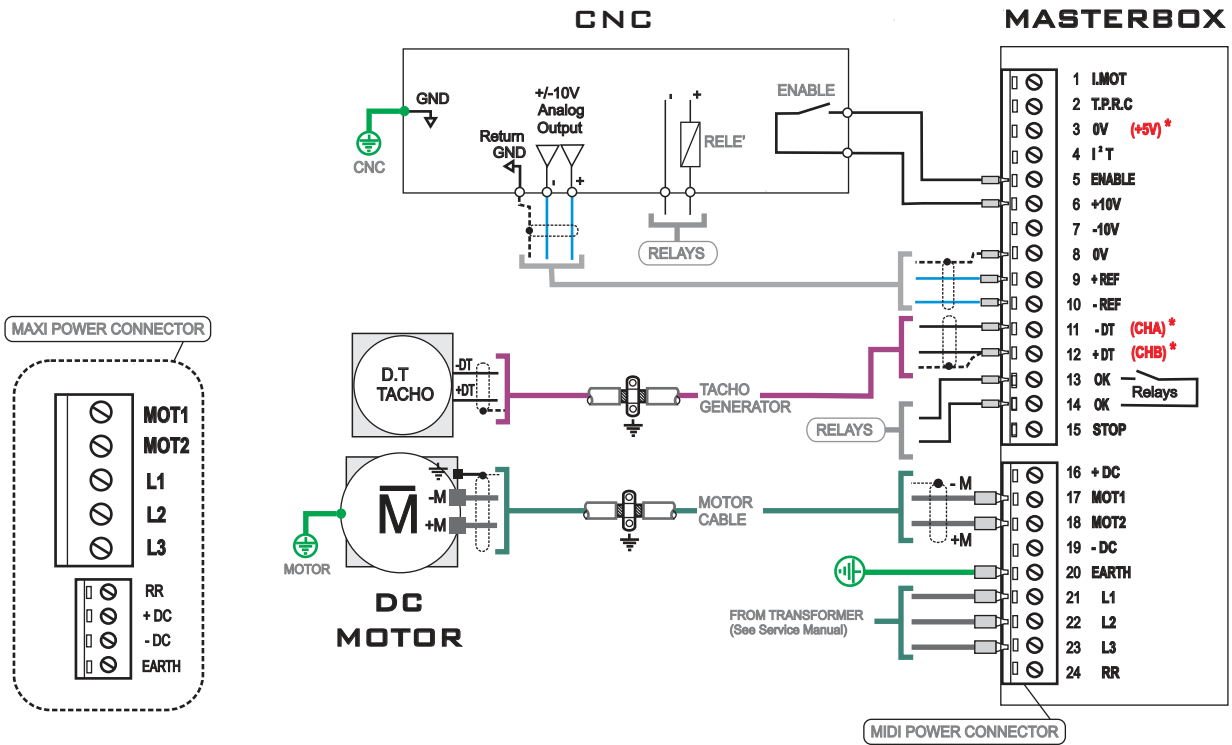

* Available version with encoder feedback. Terminal 3 becomes + 5V, terminal 11 becomes CHA, terminal 12 becomes CHB.

Technical alteration reserved. Specification subject to change without notice. All rights reserved