

MICROPHASE

Technology & Performance

Speed One

SERVO AMPLIFIER FOR BRUSHLESS & BRUSH DC MOTORS



Brushless
&
dc Motor Drive

Service Manual



Declaration of conformity

DC & BLDC SERVODRIVES

Product name: DC1C-XXX
DC1L-XXX
SP1-XXX
SP1L-XXX
MCD1-XXX
TRXL/B-XXX
TRXL/C-XXX
MUDR-XXX

Manufacturer: MICROPHASE s.a.s.

Address: Via Palladio 23
36051 Creazzo (VI) Italy

MICROPHASE s.a.s. assures that the drives listed above meet the following European Norms Standard:

in accordance with EC Directive 2014/30/EU (EMC Directive)

EN 55022, EN 61000-4-2

in accordance with EC Directive 2014/35/EU (Low Voltage Directive)

EN 61010-1

WARNING - Risk of damage and/or personal injury

This drives doesn't contain any user serviceable part. Attempting to replace any internal component, may result in damage to the unit and/or personal injury. This may also avoid the warranty.

All the informations and concepts included in this user guide are copyright, and are supplied to the user with the understanding that it may not be copied, disclosed or duplicated in whole or in part for any purpose not authorised by the factory. All specifications are subject to change without prior notification.

Print in Italy rev.08/2017



Index

Chapter 1

1.1 Safety and note	4
1.2 Operation mode and feedback	5
1.3 Model and size	6
1.4 View product	7
1.5 Ambient conditions	8
1.6 Ventilation	8-9
1.7 Dimensions	9
1.8 Signals input and output	10-11
1.9 Potentiometer adjustments	12
1.10 Indicator Leds and protections	13
1.11 Internal adjustments	14-15

Chapter 2

2.0 Power supply construction	16-17
2.1 About Connections	18
2.2 Ground Connections	19
2.3 Brushless motor Connections with encoder + hall feedback	20-21
2.4 Brushless motor Connections with fa-coder feedback	22-23
2.5 Brushless motor Connections with only hall feedback	24-25
2.6 Brush D.C motor Connections with Encoder feedback	26-27
2.7 Brush D.C motor Connections with Armature feedback	28-29
2.8 Brush D.C motor Connections with Tachogenerator feedback	30-31
2.9 Velocity Speed input	32
2.10 REQ torque input	33
2.11 Start input (Enable)	34
2.12 Current monitor output	34

Chapter 3

3.1 Adjustements with encoder feedback	35
3.2 Adjustements with armature feedback	36-37
3.3 Speed offset adjustments	37
3.4 Adjustements with tachogenerator feedback	38
3.5 Current adjustments	39
3.6 Ramp time adjustments	40
3.7 Dynamic adjustment	41
3.8 Troubleshooting	42

1.1 Safety and note

Caution

Users must keep well clear in mind that this motion control equipment is capable of producing high forces and rapid movement so they must be used with attention especially during the application program's development.

This motion control equipments are sold as end-users products to be installed only by practical staff in accordance with all local safety laws and regulations. The device have to be enclosed such that any part is not be accessible while the system is powered on.

We strongly reccomend to follow these recommendations in order to avoid wrong uses of the equipment that may be impaired all the protections provided by the device.

Please read these notes carefully before powering up the drive

It is very important meet all applicable safety requirements during installation and operating of any motion control equipment. Any installer has to assume the responsibility to ensure that he recognizes and complies all the relevant safety standards. Any installation, not meeting the safety requirements, may damage the equipment or injury the user.

This motion control equipment shoul be handled, installed, setted-up and maintenanced only by competent personnel expert and trained in the installation of motion control electronic equipment. Such technicians should be aware of potential electrical and mechanical hazards. Shall never believable or have any responsibility if the products have been improperly stored, installed, used or maintained, or if the costumer has permitted any unauthorized modifications, adjustments, and/or repairs to the products.

Simbols security standard



Warning of dangerous current present

In case of doubt or in any case you don't know as to behave yourself, before access to the drive, power off the device and wait until all the leds are turned off.
May you have attention when you touch the drive because it may be hot.



Danger Sign

All the circuits in the Drive are potential sources of severe electrical shock, so follow these rules to avoiding possible personal injury.

- Power off the drive and wait until all the leds are turned off before touching, removing, connecting or any other critical action.
- Never disconnect any connectors before powering down the drive

1.2 Operation mode and feedback

Description

This is a drive capable of piloting both rotary **AC brushless** motors and **DC brush** motors, up to 3Nm. It's a High Performance full four quadrant drive. The mosfet output power stage is controlled by a 20 Khz PWM (Pulse Width Modulation) signal that allows it to drive servo motors where high dynamic performance and precise speed is required.

Operation mode

DESCRIPTION		
SPEED CONTROL INPUT	It is speed piloting using an analogue reference (differential or common mode)	STANDARD
TORQUE CONTROL INPUT	It is torque piloting using an analogue reference. This function allows you to control the current from the drive.	STANDARD

General characteristic

DESCRIPTION		
START INPUT	Start input, enable the drive with range from $\geq 9V_{dc}$ to $+30V_{dc}$ (min/max)	STANDARD
FAULT OUTPUT	Fault drive, open collector output 50mA max. (Normally closed, opens when in protection mode)	STANDARD
2 ANALOG OUTPUT	1 motor velocity monitor "TEST", with range $\pm 8 V_{dc}$ output 1 current monitor "CURR", with range $\pm 8 V_{dc}$ output	STANDARD
LED INDICATOR	Five LEDs are located just in front of the potentiometers and show the current state of the drive	STANDARD

Velocity feedback

Closing the velocity feedback loop to motor may be done in several different ways to accommodate most applications. This types of velocity feedback are available with these Brushless or DC motors.

- AC Brushless motor with Hall effect + encoder
- AC Brushless motor with Fa-coder
- AC Brushless motor with Hall effect (internal PWM Armature)
- DC motor with encoder
- DC motor with internal PWM (Armature)
- DC motor with tachogenerator

1.3 Model and size

Model available

POWER SUPPLY		
Model 12	8 - 28 Vdc*	14Vdc**
Model 65	20 - 84 Vdc*	60Vdc **
Model 100	30 - 130 Vdc*	100Vdc **
Model 130	35 - 165 Vdc*	130Vdc **

* Power supply min/max **Typical

The power supply voltage has to be a transformer-isolated voltage

Size available

CURRENT		
Size	Rated current (A)	Peak current (A)*
2/4	2	4
4/8	4	8
7/14	7	14
10/20	10	20

*Peak current during 2 sec

Max size available for model 130 is 7/14A

Specifications

TECNICAL DATA CHARACTERISTICS	
Supply voltage output	0,9 Vdc Input
PWM frequency	20Khz
Operating temperature	0/+45°C
Storage temperature	-10/+70°C
Drift analog input	0,5uV/°C
Analog inputs (+/-VEL)	+/-10Vdc max, impedance 20Kohm cad.
Current monitor output (CURR)	+/- 8Vdc = Peak current
Velocity monitor output (TP1)	+/- 8Vdc = max velocity
Power supply output (+5V)	+5Vdc max 130 mA
Power supply output (+/-9,8V)	+/-9,8Vdc max. 4mA
Encoder max. frequency	300Khz with level $\geq +2,8/24$ Vdc min/max
Fault drive output	NPN 50mA max.
Start input	$\geq +9V/+30$ Vdc (min/max)
Band width (current)	2KHz
Band width (velocity)	150Hz
Minimum Inductance motor	400uH
Weight	0,35kg 10.6oz
Contaminants	2° or better (Norms EN60204 e EN50178)
Altitude	Up to 1000m without restrictions, from 1000 to 2000m power derating 1,5%/100m
Flammability rating 94V-0	Cover material, the PCB and the electronic component meet 94V-0

1.4 View product

- (1) Product Label
- (2) Fixing screw
- (3) Product Cover
- (4) Solder bridges
- (5) Adjustment zone
- (6) Four calibration Potentiometers
- (7) Leds
- (8) TEST point (Encoder, Tacho or Armature velocity)
- (9) M1 Signal terminal 16 pins MC1,5/16-ST-3,81 (pitch 3,81)
- (10) POWER Terminal 5 pins GMST 2.5/5-G-5,08 (pitch 5,08)

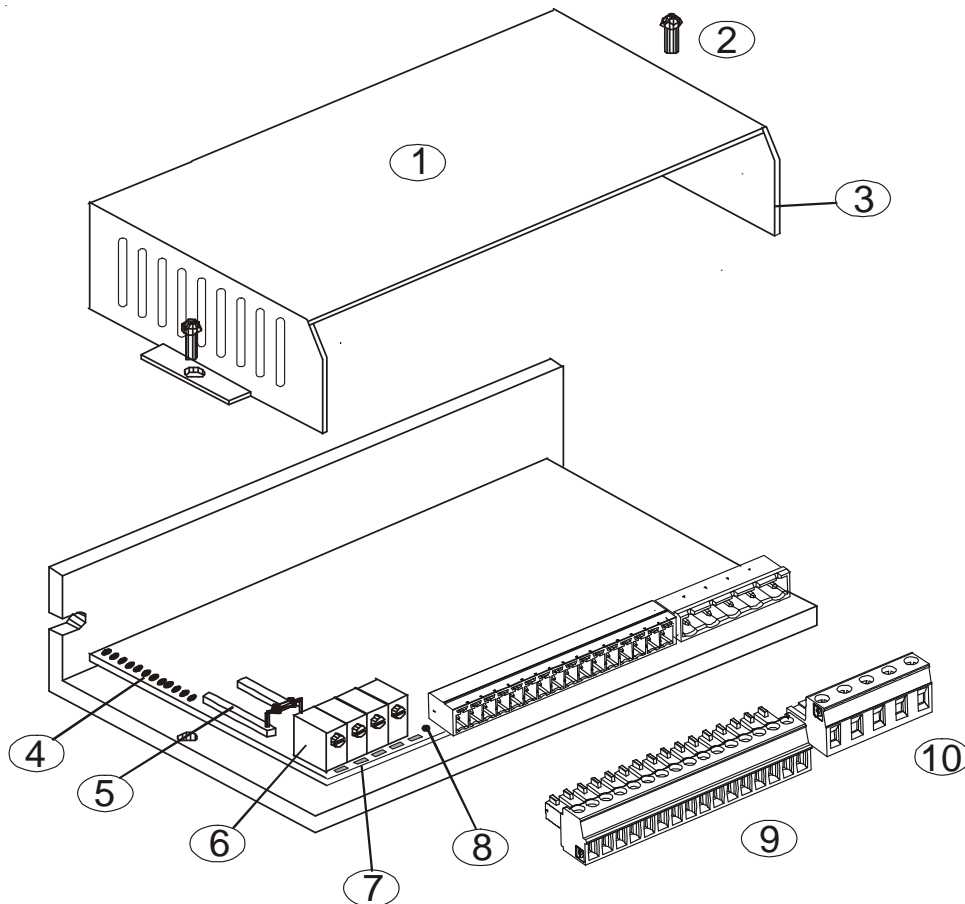

1.5 Ambient conditions

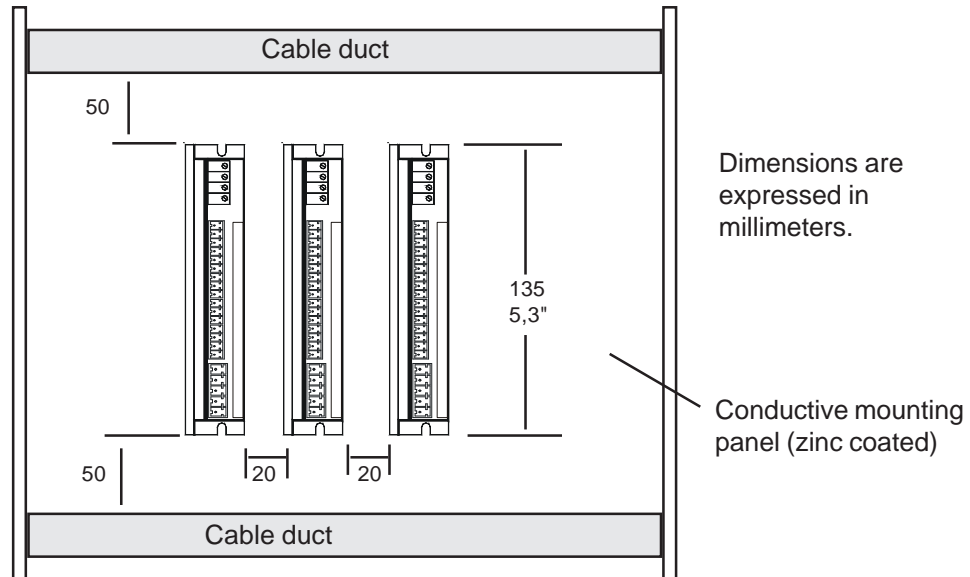

Positioning in the electrical box

Follow the instructions in the positioning of the servodrive in the electrical box.

- The drive is natural convection air flow cooled.
- To ensure the drive cooling and make the installation easier for the operator it must be installed vertically leaving a free space of at least 20 mm (0,78 inch) on each side of the device. The converter must be mounted vertically on the electrical box. In case you want to mount it horizontally, remove the cover.
- The electrical box must have suitably filtered air vents.
- Leave the necessary space both above and below the converters.
- Keep the drive from excessive mechanical vibration

Notes during the assembly

Caution: during the wiring of the servodrive in the electrical box, make sure that do not enter leading wires of copper or iron chips through the slits. Before performing the work cover the holes with a piece of paper tape. Naturally finished work this tape is removed.

1.6 Ventilation

This servodrive are intended only for use in close locations. Ambient characteristics: operating temperature from 0 to +40°C. Humidity limits between 5% to 95% non condensing (Pollution degree 2 or better).

Supplementary ventilation may be requested in accordance to size. See the table below.

MODEL	SIZE			
	2/4	4/8	7/14	10/20
12	N	N	N	N
60	N	N	N	N
110	N	N	N	V
130	N	N	V	N.A

N = Standard radiator (operating ambient temperature from 0 to 40°C)

V = Standard radiator + supplementary ventilation (operating ambient temperature from 0 to 45°C)

NA = Not available

Supplementary ventilation

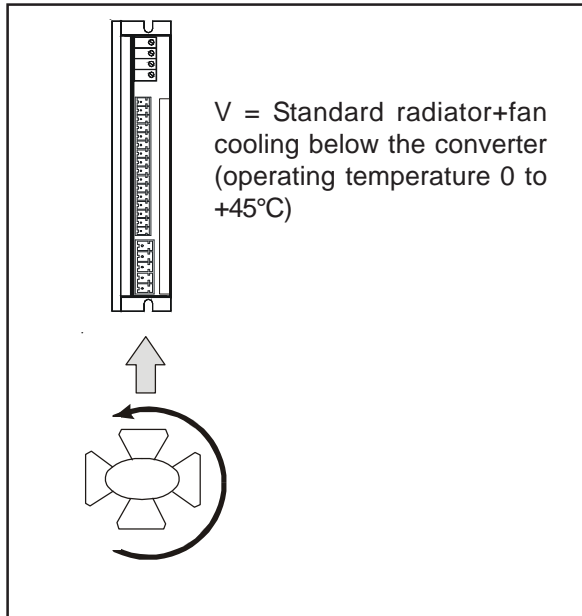

Mounting position

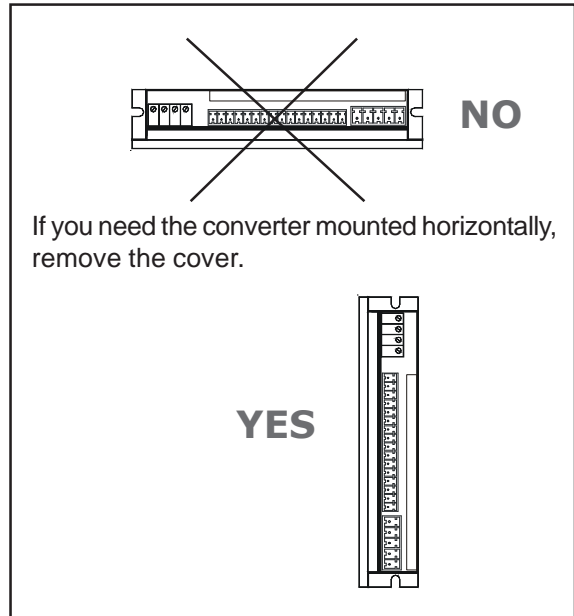

1.7 Mechanical dimensions

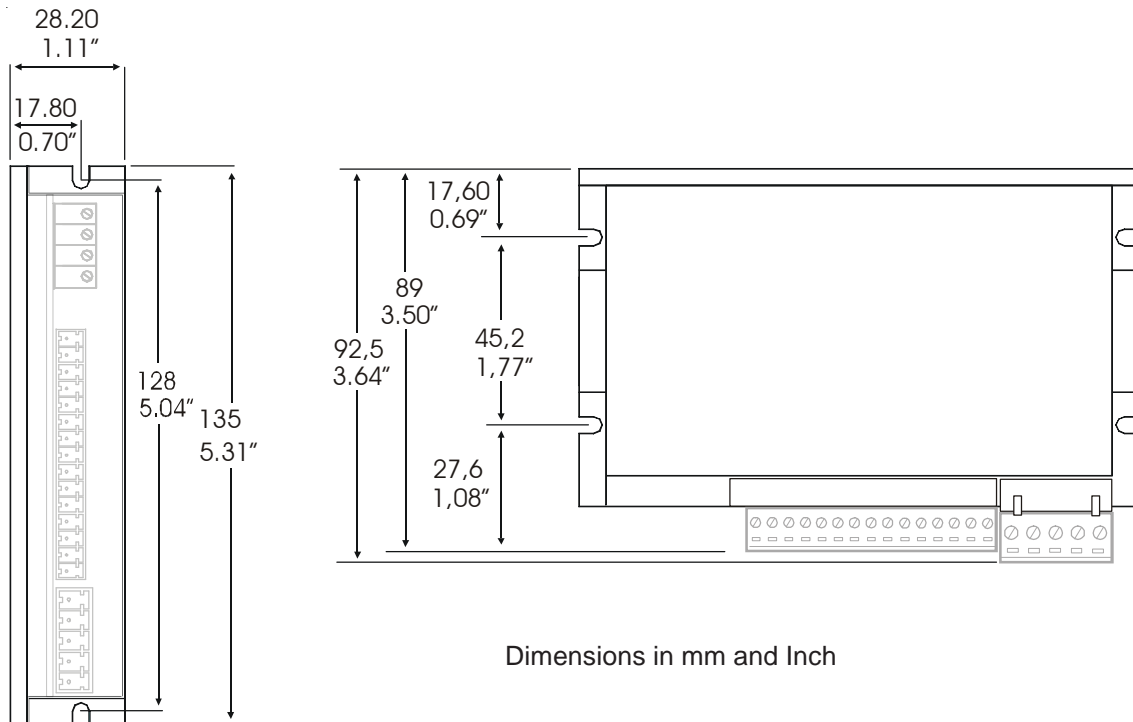

1.8 Signals input and output

The figure below shows the view of the converter terminals.

M1 Signal terminal 16 pins "type MC 1,5/16-ST-3,81"

POWER Terminals 5 pins "type GMST 2,5/5-G-5,08"

On the test point "TEST" you can see the signal of velocity speed. The output from 0 to $\pm 8V$ is from zero to maximum speed. At this point you can analyze the signal when you enable one of the following velocity feedback.

- Encoder
- Armature
- Tachogenerator

NOTE: Depending on the type of motor to drive "**Brushless DC** or **DC Brush**", follow the links relating to such applications.

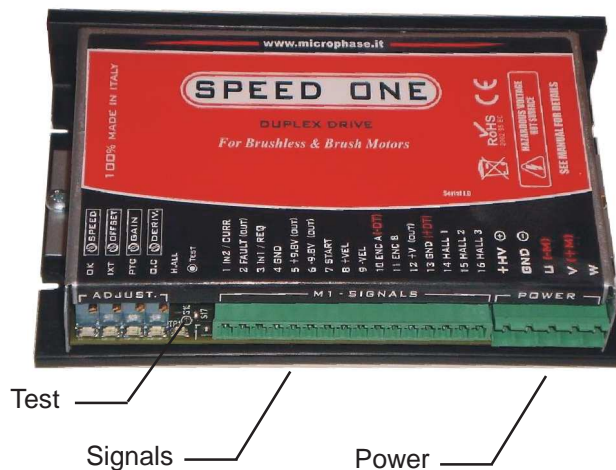

Power connector

POWER	
+HV (IN)	Positive Power supply input
GND (IN)	Negative Power Supply input (GND)
U (OUT)	Motor connection U phase, or -M
V (OUT)	Motor connection V phase, or +M
W (OUT)	Motor connection W phase

NOTE: See also the connection diagrams in Chapters 2.X

Signal inputs and outputs

M1 CONNECTOR	
1 CURR / IN2	This signal can be used in 2 distinct modes: Current motor monitor (OUT): +/-4Vdc=Rated current, +/-8Vdc=Peak current output in Volts. This output may be used to monitor the torque the motor is producing (Standard setting) IN2 setting (IN): Is possible setting this terminal for Limit sw input (contact factory)
2 FAULT (OUT)	Fault drive, open collector output max. 50mA Normally closed, opens when the drive in protection mode
3 REQ / IN1	REQ. , can be used in 2 distinct modes: 1) Motor Current limit mode (by REQ setting) : A motor current limit mode connect an external resistor to GND reduces the maximum current. Connect a 1/4W or 1/8W resistor between the TPRC (pin 3) and GND (pin 4) terminals. A 47Kohm external resistor reduces the current by 50%. (Note: The drive velocity loop remains active) 2) Torque request (by REQ setting) : Range: +/- 10V, which corresponds to the drives peak current output. In this mode the velocity loop is automatically disabled. IN1 setting (IN): Is possible setting this terminal for Limit sw input (contact factory)
4 GND	Signal Common Ground Corresponds to power supply's negative GND input
5 +9,8V (OUT)	Power supply +9,8Vdc max 4mA
6 -9,8V (OUT)	Power supply -9,8Vdc max 4mA
7 START (IN)	Positive drive enable with range $\geq +9Vdc$ min. to +30Vdc max
8 +VEL (IN)	Reference Positive differential input (Velocity command)
9 -VEL (IN)	Reference Negative differential input (Velocity command)
10 ENC A (IN) or -DT (IN)	Encoder input Channel A (High logic level from $\geq 2,8V$ to +24Vdc max. Low logic level $\leq 1,5V$). Is possible setting this terminal for -DT tachogenerator input
11 ENC B (IN)	Encoder input Channel B (High logic level from $\geq 2,8V$ to +24Vdc max. Low logic level $\leq 1,5V$)
12 +5V (OUT)	Power supply +5V max. 130mA
13 GND	Signal Common Ground. Corresponds to power supply's negative GND input.
14 HALL 1 (IN) 15 HALL 2 (IN) 16 HALL 3 (IN)	Hall Sensor inputs from the motor. Each input has a pull-up resistor of 1 Kohm to internal +5V (High logic level $\geq 3,2V$, Low logic level $\leq 1,5V$)

1.9 Potentiometer adjustments

The converter is equipped with 4 trimmer with the following meanings:

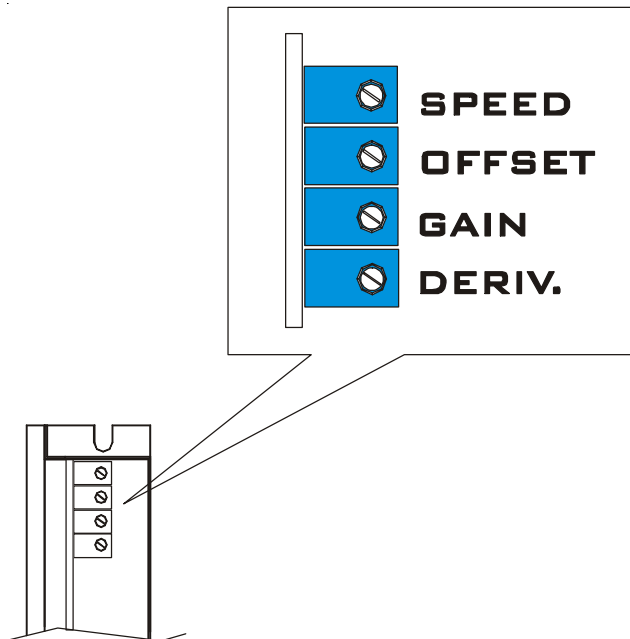

FUNCTION	
SPEED	Motor fine speed calibration. With rotating clockwise (CW) or counterclockwise (CCW) is possible increase / decrease the speed of the motor with range + / -25%
OFFSET	Offset adjustment. Allows the balance to zero motor speed. Adjust this potentiometer to cancel any motor speed offset when the Velocity input is zero. (Max Velocity compensation +/- 250mV).
GAIN	Gain potentiometer. This adjustment improves the dynamic behavior of the motor. With a clockwise (CW) we increase the readiness and response of the motor. With a clockwise turn (CW) we increase the gain of the PI "internal speed loop".
DERIV.	Derivative potentiometer. Acting in a clockwise (CW) can dampen any oscillations of the motor due to a high moment of inertia of the load.

NOTE:

- In Chapter 3.7 explains how to dynamically tune the motor by acting on the 2 trimmer GAIN and DERIV.
- All potentiometers are disabled in Torque mode

1.10 Indicator Leds and protections

The protections are all displayed by five LEDs on the front of the drive. It also comes with a series of protections designed to safeguard in case of malfunction, the drive and the motor.

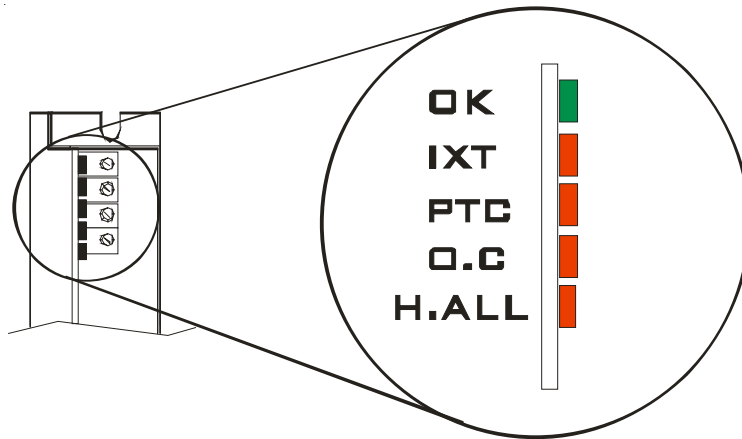

FUNCTION	
OK GREEN	Normally ON. Indicating the proper operation of all functions. It turns OFF in case of any anomaly "except protection intervention IxT". The faults that affect this LED are: Over/Under input voltage. Over temperature (PTC). Short Circuit (O.C), outputs shorted to each other or to ground or missing Hall.
IxT RED	Normally OFF. This indicator is lit if the converter exceeding the limit calibration of the rated current of the motor. When the current drawn back under the nominal pre-set, the alarm will auto resets and the LED turns off by itself.
PTC RED	Normally OFF. This indicator is lit when the internal temperature of the drive reaches 75°C . Remove power and wait for the drive to cool before re-applying power. The operation causes the blocking of the drive and the storage of the alarm. NOTE: A fan, heat sink or air conditioner may be needed to remedy the problem.
O.C RED	Normally OFF. Indicates that between the motor terminals and/or ground, has been a short circuit. The operation causes the blocking of the drive and the storage of the alarm. Remove power supply and examine the motor connecting leads for shorts, before re-powering the converter to reset the alarm.
H.ALL RED	Normally OFF. If lit Indicates that the Hall signal is missing, or is missing the power supply +5V. Check the Hall signals with a voltmeter or an oscilloscope.

In chapter 3.8 it explains the possible reasons for the alarms of the converter.

1.11 Internal adjustment

If changes need to be made to the internal drive setting powering, please wait at least 30 seconds after the power has been removed and the OK LED is off.

All of the personalizations are located inside of the DRIVE. (See figure above)

To gain access to the adjustment pads and the Solder bridges, unscrew and remove the cover.

Solder point standard configuration

Solder bridges standard position are setting by factory for:

- Brushless setting
- Encoder feedback
- Ramp time disabled
- Standard Dynamic constant

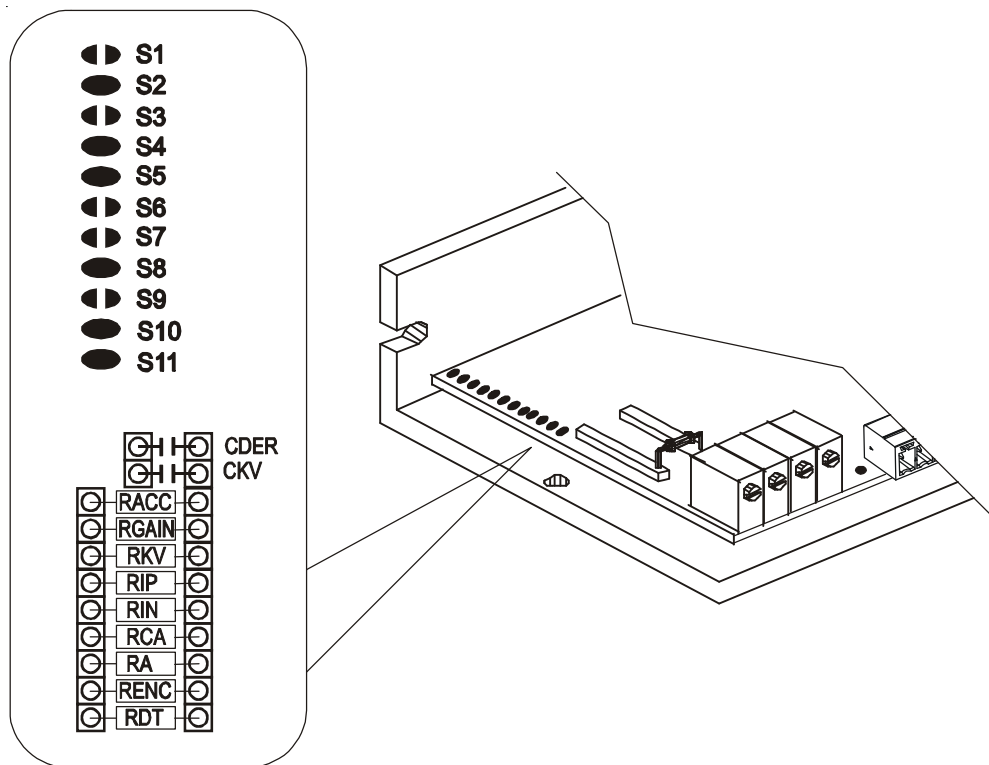

Note: In the various configurations with **Brushless** or **DC Brush** motor (see Chapters 2) In the left-hand page for each chosen velocity feedback, is shown a typical connection with the notes of wiring of the converter.

Adjustement zone

	FUNCTION
RDT	Tachogenerator resistor adjustment
RENC	Encoder resistor adjustment
RA	Armature resistor adjustment
RCA	Droop compensation for internal motor resistance (RI)
RIN	Rated drive current resistor
RIP	Peak drive current resistor
RKV	Resistor value that respectively form the proportional/integral network of the velocity Loop gain. Disabled by opening solder bridge S4. Standard value 100k and 47nF.
GAIN	Changes static gain in the velocity loop. Open solder bridge S5 and insert RGAIN if a change is required. Consult factory for the correct value.
RACC	Resistor for setting acceleration time function. See Chapter 3.6
CKV	Capacitor value that respectively form the proportional/integral network of the velocity Loop gain. Disabled by opening solder bridge S4. Standard value 100k and 47nF.
CDER	Derivative constant capacitor, increases the velocity loop derivative constant. Consult factory for the correct value.

Solder bridges

Note: For any feedback available, are listed in the various chapters related settings (see Chapter 2)

	SOLDER POINT
1	Normally open (OFF) With S1 open the drive is set for Brushless motors . If closed (ON) the drive is setting for D.C motors
2	Normally closed (ON) Don't touch
3	Normally open (OFF) See Chapter 3.6 "Ramp time adjustment". If closed insert RACC resistor
4	Normally closed (ON) If Open , install components in the adjustment zone, for the dynamic velocity value CKV and RKV. (Standard value RKV=100Kohm , CKV= 47nF).
5	Normally closed (ON) If Open you must insert the GAIN resistor. (Static Gain). Standard value= 27 ohm
6	Normally open (OFF) If closed, when the IxT protection operates the green led OK (and the output FAULT) goes off.
7	Normally open (OFF) If closed the drive is set is for the armature feedback. Insert also the resistance RA and RCA
8	Normally closed (ON) In this position the drive is set is for the encoder feedback. If Open (OFF), are enable other type of feedback.
9	Normally open (OFF) If closed setting the drive for PWM+DIR command (optional)
10	Normally closed (ON) Open S10 (OFF) for tachogenerator feedback
11	Normally closed (ON) If open (OFF), the alarm protection for missing Hall Effect Signals will not disable the drive.

2.0 Power supply construction

Normally the power supply is built by a transformer, a bridge rectifier and a filter capacity. Alternatively, the power supply can also be of switching type, in this case refer factory by the appropriate sizing. The converter have to be supplied from an isolating rectified transformer secondary or a DC isolated power supply.

Transformer

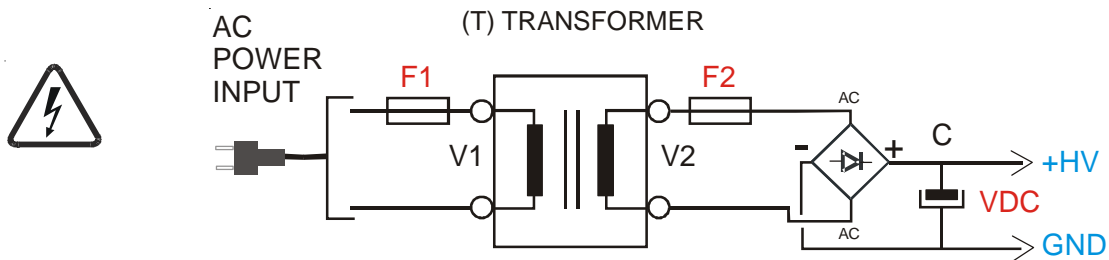

Voltage:

The primary voltage depends on what is available locally for a single phase. The secondary voltage is calculated from the motor's voltage at the required operating speed.

The secondary voltage VDC is:

$$VDC = V2 * 1,41$$

Example: If the secondary transformer V2 is 45Vac, the VDC output is $45 * 1,41 = 64Vdc$

PAY ATTENTION:

- The drive has zero signal GND in conjunction with the zero power GND, thereby preventing the following links:
- Use a standard heavy duty power transformer without center taps on the secondary as shown in the schematic above.
- DO NOT USE AN AUTO TRANSFORMER.

Power transformer (T)

The transformer's nominal power is calculated based upon the sum of power from the single motors driven:

$$P(VA) = Pn1 + Pn2 + ..$$

$$Pn \text{ Motor} = N * Cn / 9,55$$

- Where:
- Pn Motor** = Power absorbed motor in (W)
 - N** = Max. speed of motor in RPM.
 - Cn** = Nominal torque of motor in (Nm).

Note: In multi-axis applications, the transformer's power can be downgraded by 30%. If the max. power transformer calculated is over 6KVA contact the factory.

Voltage motor

If the secondary voltage of power supply is VDC, the Vdc motor is calculated by the formula:

$$VDC = Vdc \text{ motor} / 0,83$$

Where the Vdc motor is a sum of FCEM + the drop $R * I$ for the winding resistance motor

$$Vdc \text{ motor} = E + (Ri * In)$$

The FCEM of the motor "E", may be calculated by the formula:

$$E = Ke * N^\circ / 1000$$

Example: Brushless motor with the following data:

$I_n = 5$ (A)

$R_i = 1$ (Ohm)

$E = 48$ (V) at nominal speed 3000 (RPM)

$$V_{dc} \text{ motor} = 48 + (1 * 5) = 53V$$

$$VDC = 53 / 0,83 = 63,8V$$

63,8V is the **VDC** voltage request for the power supply. You'll use a transformer with the secondary $V_2 = 64 / 1,41 = 45V_{ac}$

When you use the transformer with $V_2 = 44/45V_{ac}$, it is correct.

Misure unit:

$E = K_e * n^\circ / 1000$ (Vdc)

$I_m = I$ motor (A)

$R_i =$ Winding resistance (Ohm)

$K_e =$ Voltage constant (V/kRPM)

$n^\circ =$ MAX speed (RPM)

Capacitor filter (C)

In regards to the capacitor filter we suggest a working voltage of:

*100VDC for Model 65

*160-200VDC for Model 100 and Model 130

Typical value is from 4700uF to 10.000uF

Capacity above the filter effect, helps to recover energy during braking of the motor.

If the converter during braking has the green LED that flashes you must increase the value of the capacitor (eg. 10.000uF from a 20.000uF)

Fuses (F1) e (F2)



Fuses are required on both the primary and secondary of the transformer to protect against harm to the system and the transformer itself. They need to be of the slow blow type to handle current in-rush at power-up. Locate the primary fuse (F1) on the hot leg of the AC input power and the secondary fuse (F2) on the + side of the secondary output, before the rectifier.

Primary of the transformer: Use the formula below to calculate the correct values:

$$F1 \text{ (A)} = P \text{ (VA) trasfo.} / V1$$

Secondary of the transformer: Use the table below

FUSE F2 (A)	SIZE Drive (A)
5	2/4
8	4/8
12	7/14
16	10/20

2.1 Note about connections

Multiple connection

In the case of multiple servodrives on the same power supply, make connections-type stars, see drawing back. Connect also feed converters using the shortest cable possible. If the cable length exceeds 2m, twist the + and - leads together as twisted pairs.

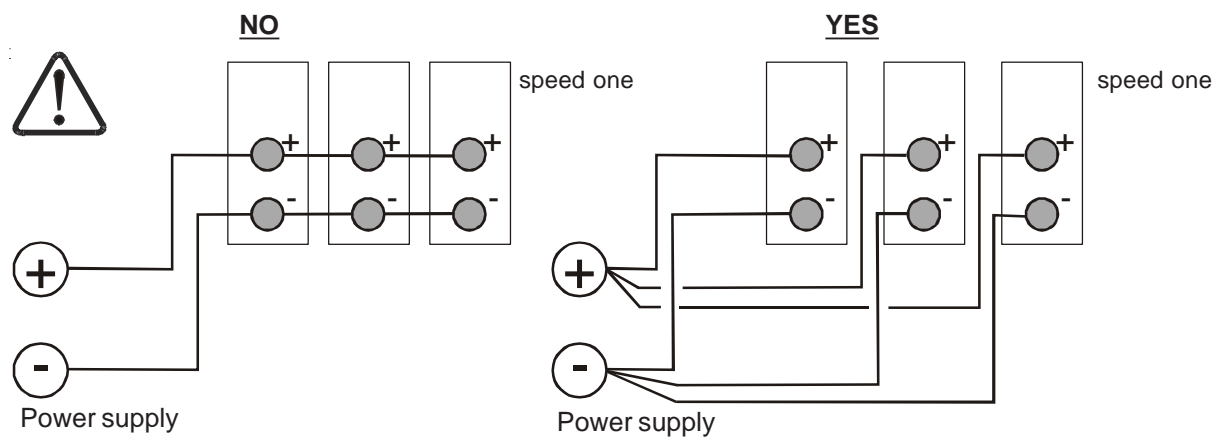

The drives have to be supplied from an isolating rectified transformer secondary or a DC isolated power supply.

EMC note

The conformity is assured only if it is installed following the precise assembly criteria expressed below. The fundamental assembly characteristics are summarized below:

- 1) The correct ground connection of predisposed parts.
- 2) Using the division of cables technique. Separate power cables from signal cables.
- 3) Use of shielded cables, both for power connection (to the transformer and the motor), and for signal connection (also to the controller).
- 4) Use of appropriate network to filter the line (transformer input), from disturbances conducted or produced by the drive. (series of filters released are available for this purpose)

2.2 Connection to earth and ground

Make sure that the servodrive and the motor are connected to earth in accordance with the current norms. This connection must be done by using a copper bar, mounted on insulating supports:

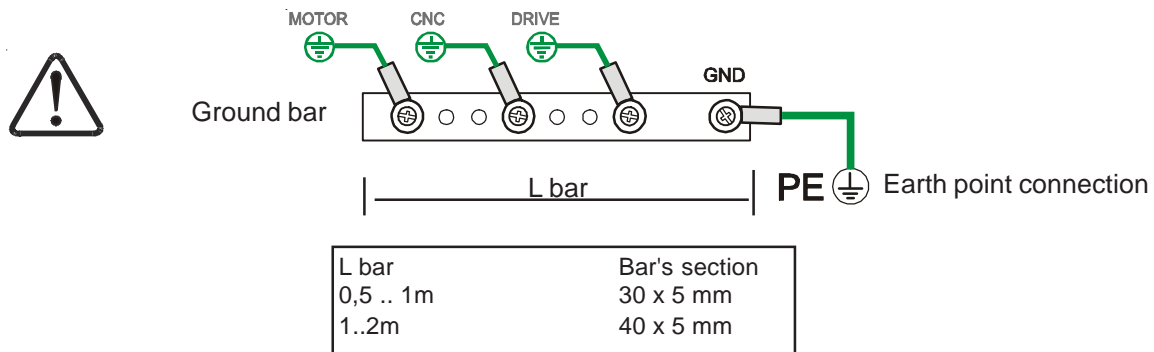

then follow these indications:

1. Connect to the ground bar:
 - the internal "0V" zero voltage of the CNC;
 - the earth terminals of the PLC/CNC frames;
 - the "0V" of the auxiliary supply;
 - the CHASSIS of all drives;
2. Connect the ground bar to the zinc panel of the drive by using a screw, then connect that screw to earth.
3. Connect earth to the motor's



It suggests a conductive connection as much as possible to the chassis, or the heatsink, or the mounting panel of the electrical box.



It refers to the earth connection.

Motor and Power cable (as norm EN60204)

SECTION	SIZE (A)
1,5mm ² / 15AWG	2/4 4/8 7/14
2,5mm ² / 13-14AWG	10/20

Control signals cable (as norm EN60204)

SECTION
0,5mm ² / 20AWG

Feedback signals cable (as norm EN60204)

SECTION
0,25 - 0,35mm ² / 22 -24AWG

2.3 Brushless motor with encoder

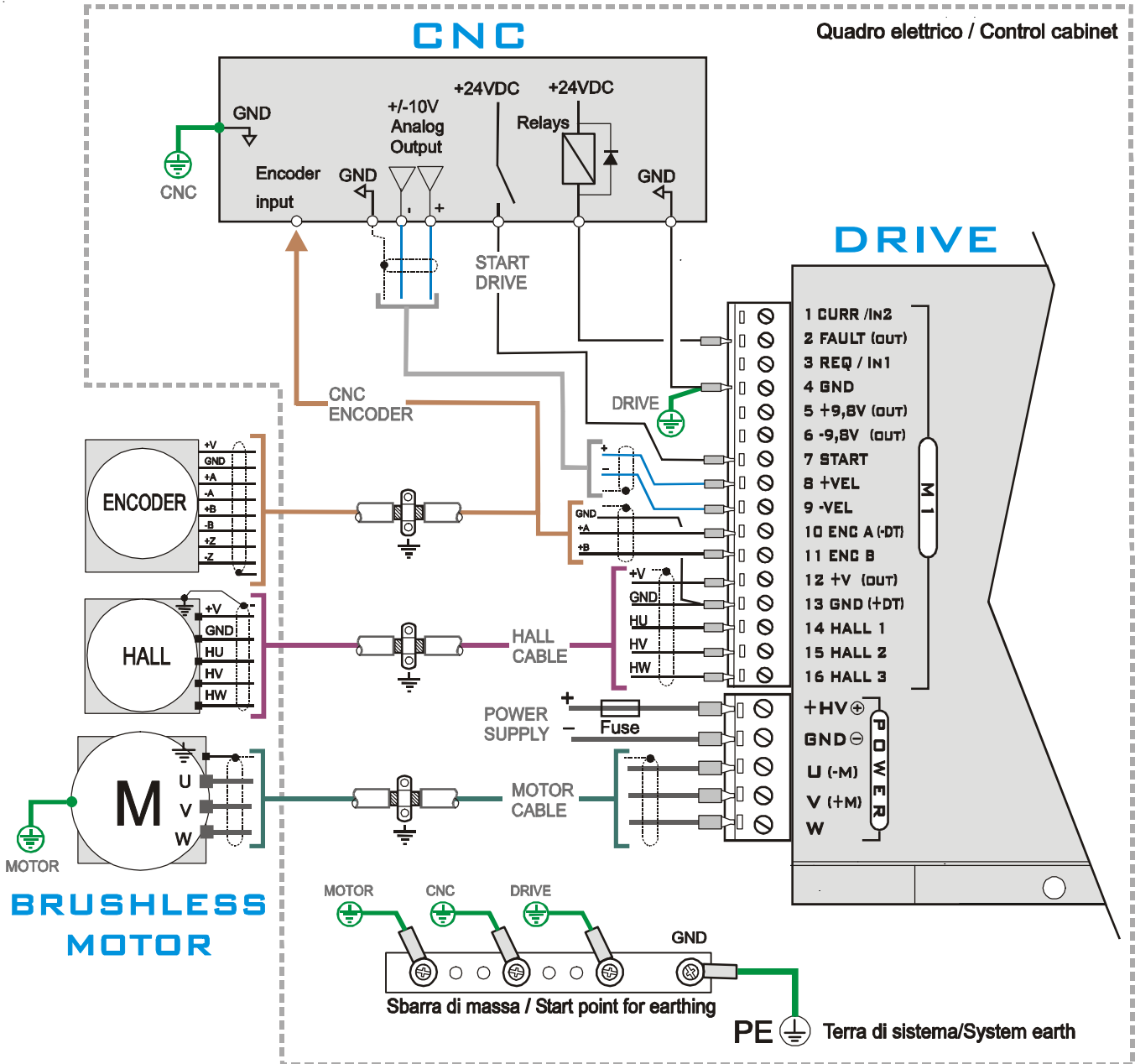

In the figure above is shown a typical connection of the Speed One in combination with a brushless motor.

The encoder with line driver output is connected directly to the control. Depart from the control wires A +, B +, GND to the converter (signals in common mode).

In the example the encoder is supply by the CNC, while the hall sensors are supplied by Drive (+V terminal 12).

It also possible to supply the encoder with the voltage present on the +5V of the drive (+V terminal 12), verifying that the absorption of the encoder does not exceed 100mA.

The converter is capable of providing 130mA max (100mA for encoder and 30mA for Hall sensors)

Hall sensors must be supplied using the internal +5V of the Drive (M1 connector 12). If an external supply is used, open solder bridge S11.

Setting for Brushless motor with encoder

In this configuration, the drive must set with the following Solder bridges and below internal setting:

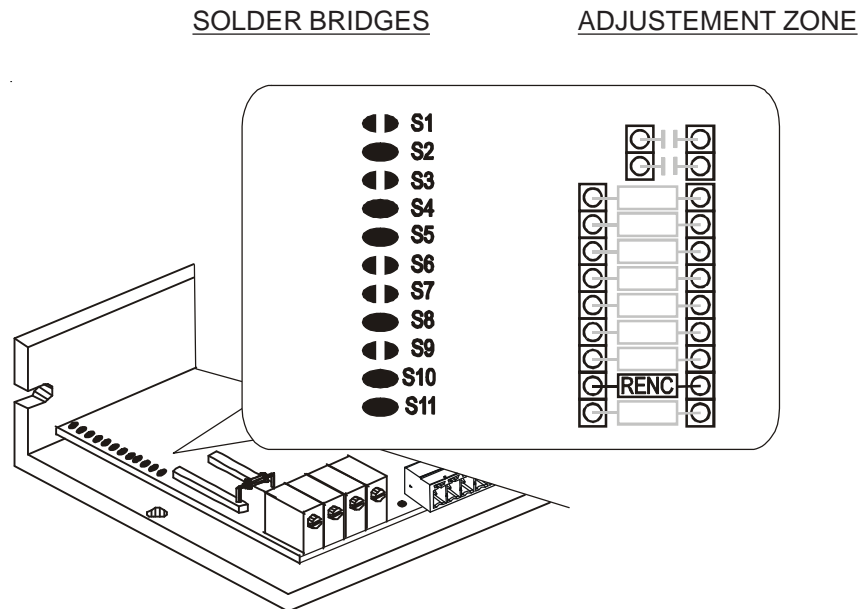

Solder Bridges set for:

- Brushless motor
- Encoder feedback
- Ramp time disabled
- Standard Dynamic constant

For the correct value of RENC resistor (speed adjustment range) see chapter 3.1

Note: On the adjustment zone are not considered here the other components used to determine other calibrations "for example. Calibration current rating etc."

2.4 Brushless con Fa-coder

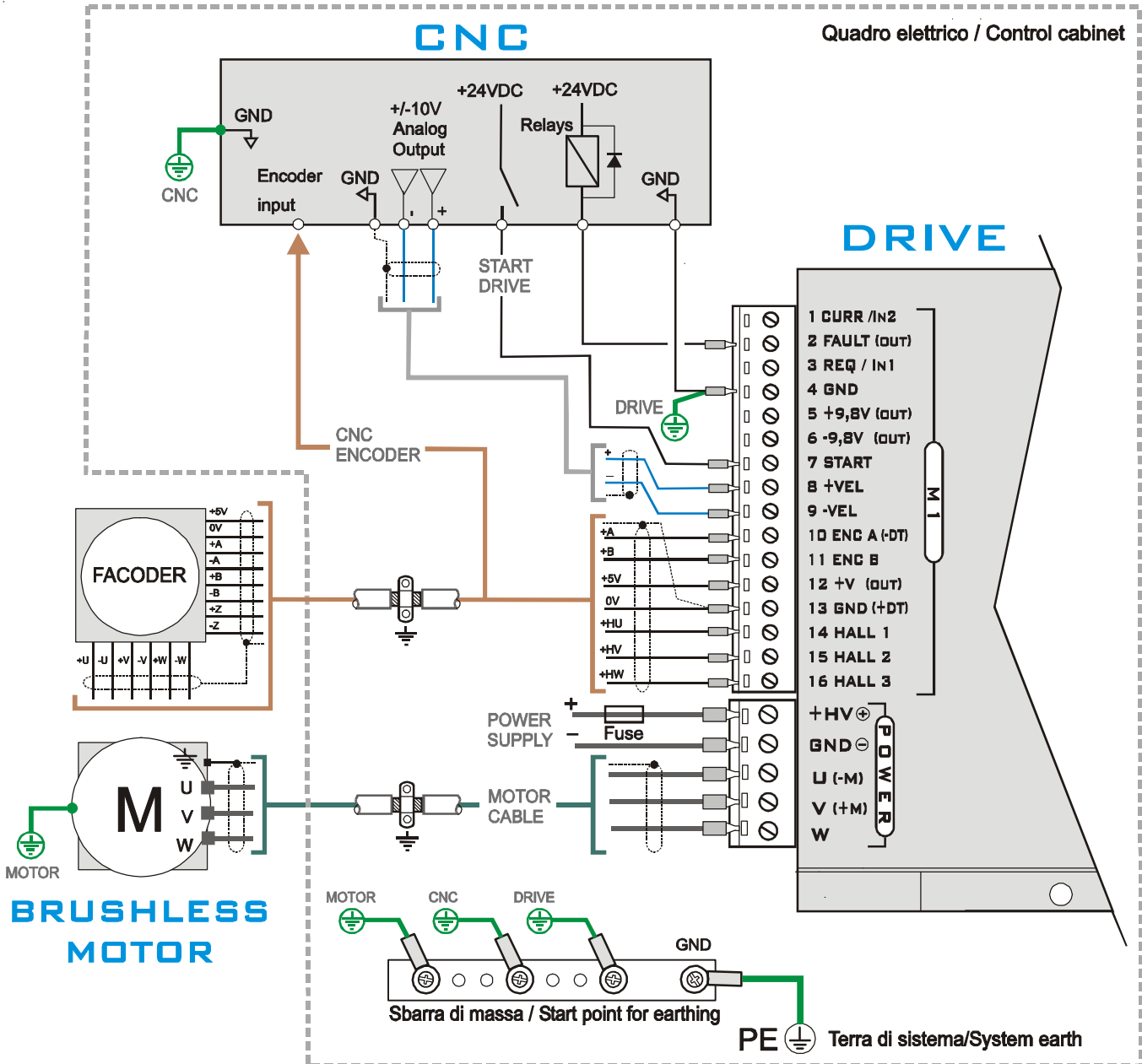

In the figure above is shown a typical connection of the Speed One drive in combination with a brushless motor. The speed loop velocity is by Fa-coder feedback. The motor is equipped with Fa-coder which provides both encoder + hall signals RS422 line driver (differential output).

The Fa-coder is supply from the drive through the power available on the terminal 12 "+5V". This power supply is capable of providing output 130mA max. Since the output signals from the converter is shared by both the CNC card, you should create a connector or terminal block support.

WARNING: The Fa-coder must be supplied using the internal +5V of the Drive (M2 connector 12). If an external supply is used for the Fa-coder, open S11.

Setting for Brushless motor with Fa-coder

In this configuration, the drive must set with the following Solder bridges and below internal setting:

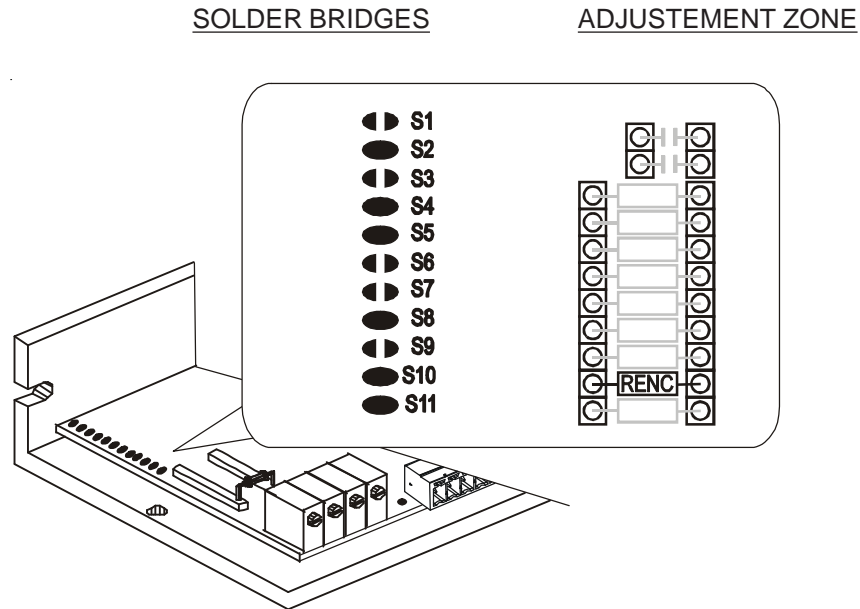

- Solder Bridges set for:
- Brushless motor
 - Fa-coder feedback
 - Ramp time disabled
 - Standard Dynamic constant

For the correct value of RENC resistor (speed adjustment range) see chapter 3.1

Note: On the adjustment zone are not considered here the other components used to determine other calibrations "for example. Calibration current rating etc."

2.5 Brushless motor with hall signals

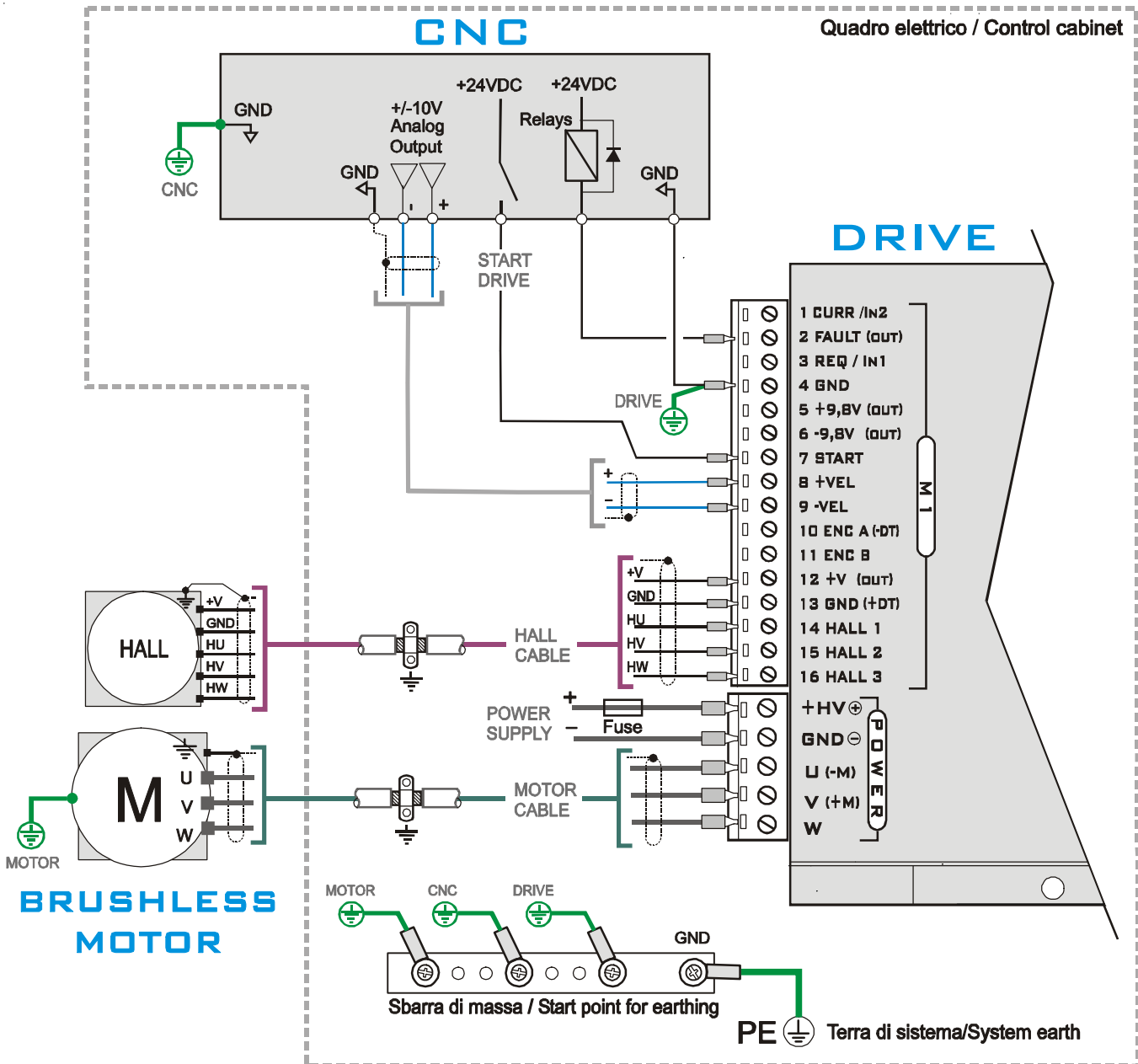

The following diagram shows an typical application utilizing a Drive with Brushless motor (only Hall signals).

These signals are used by the converter for the control of current and to regulate motor speed. The adjustment range is lower than the use of 'Encoder + Hall, but sufficiently good for many applications.

Setting for Brushless motor with hall signals

In this configuration, the drive must set with the following Solder bridges and below internal setting:

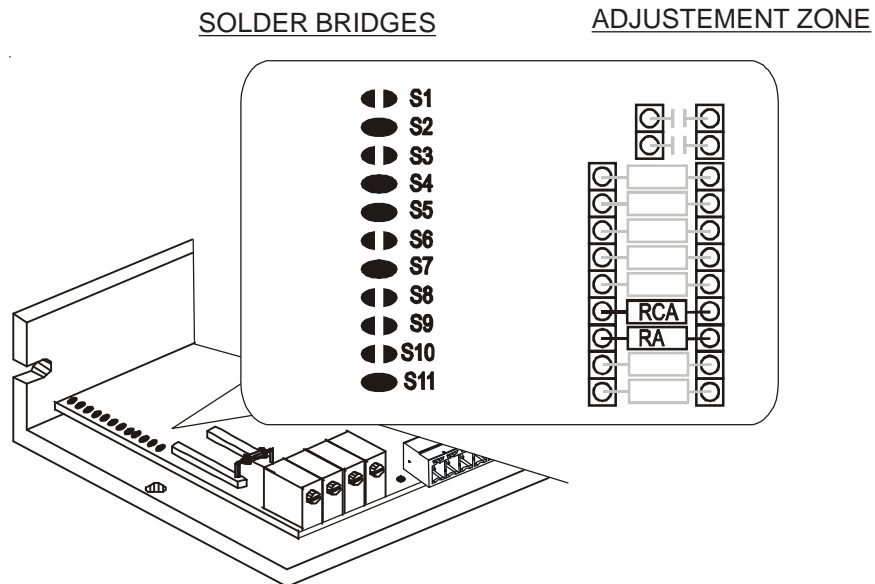

Solder Bridges set for:

- Brushless motor
- Hall feedback (Armature)
- Ramp time disabled
- Standard Dynamic constant

For the correct value of RA and RCA resistor (speed adjustment range) see chapter 3.2

Note: On the adjustment zone are not considered here the other components used to determine other calibrations "for example. Calibration current rating etc."

2.6 Brush dc motor with encoder

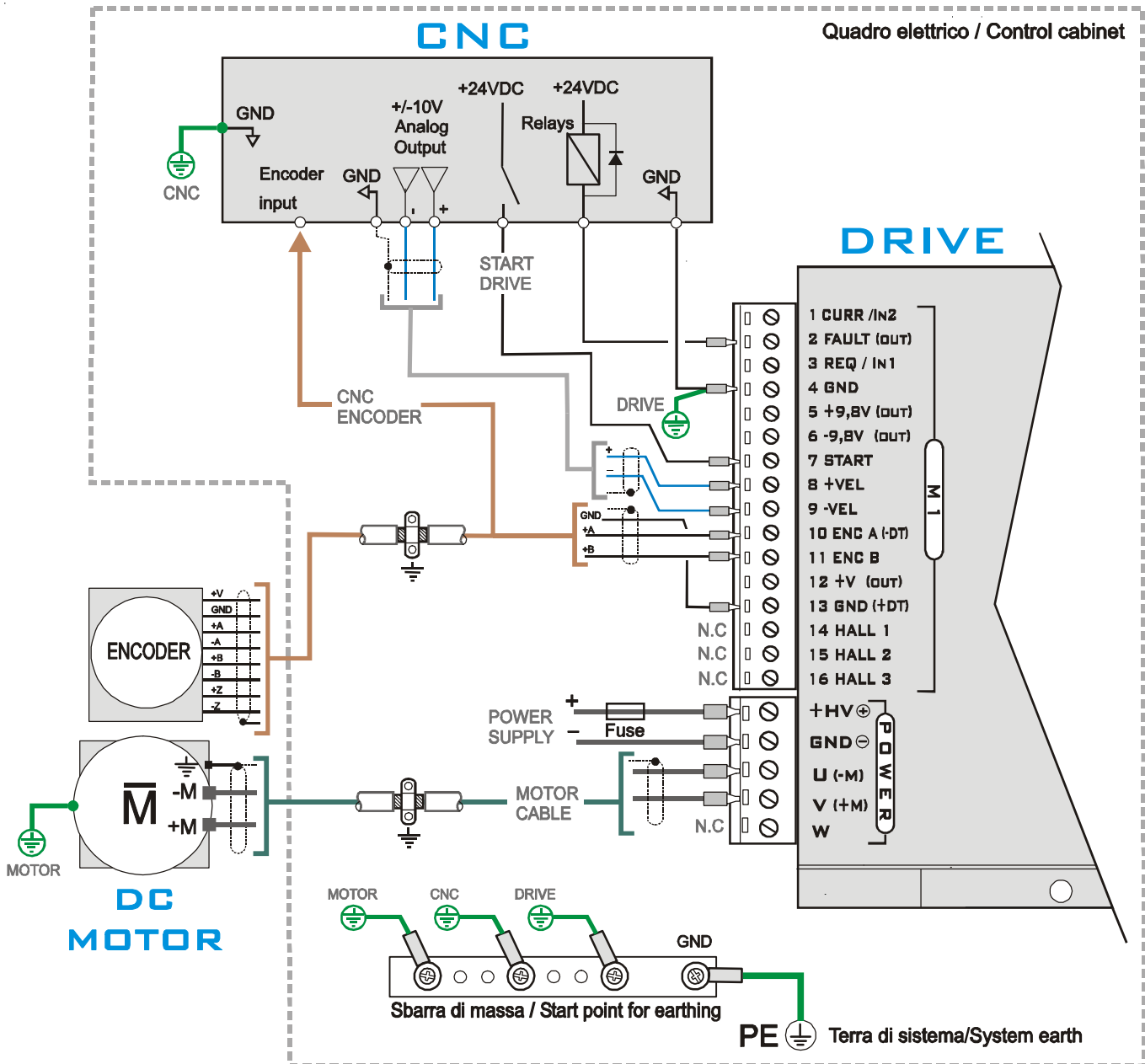

The following diagram shows an typical application utilizing a Drive with Brush motor + M and -M output are identified on the POWER connector of the product. In this case the drive is feedback from encoder. The inputs signal encoder of the drive" ENC A and ENC B" are refer with the zero control signals of CNC

The drive is made by factory in the BRUSHLESS MODE. The setting for change a brushless DC converter in DC Brush is "S1" solder brigde If open (OFF) the drive is Brushless, if closed (ON) is the drive is DC Brush

Note: In the configuration for driving DC Brush motor, the terminals 14,15 and 16 should not be connected (NC)

Setting for Brush dc motor with encoder

In this configuration, the drive must set with the following Solder bridges and below internal setting:

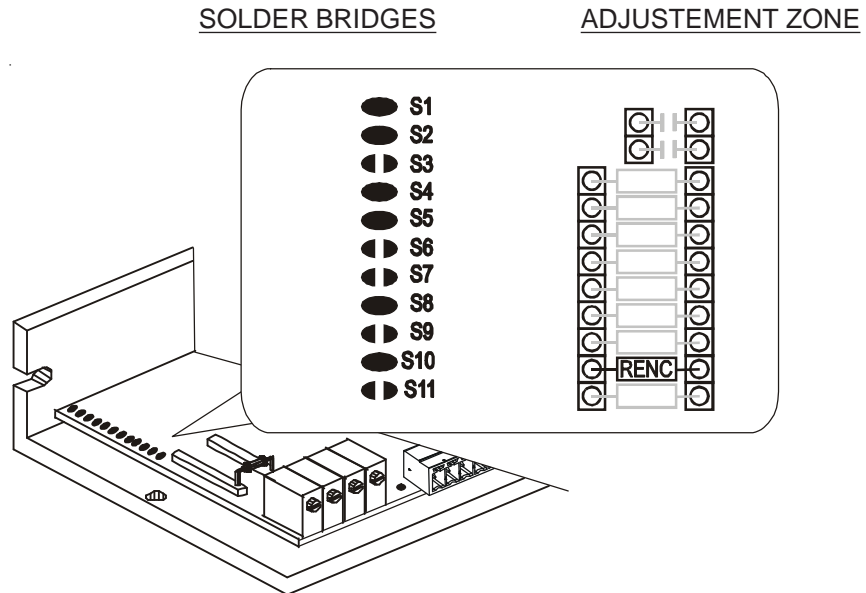

Solder Bridges set for:

- Dc motor
- Encoder feedback
- Ramp time disabled
- Standard Dynamic constant

For the correct value of RENC resistor (speed adjustment range) with encoder see chapter 3.1

Note: On the adjustment zone are not considered here the other components used to determine other calibrations "for example. Calibration current rating etc."

2.7 Brush dc motor in armature

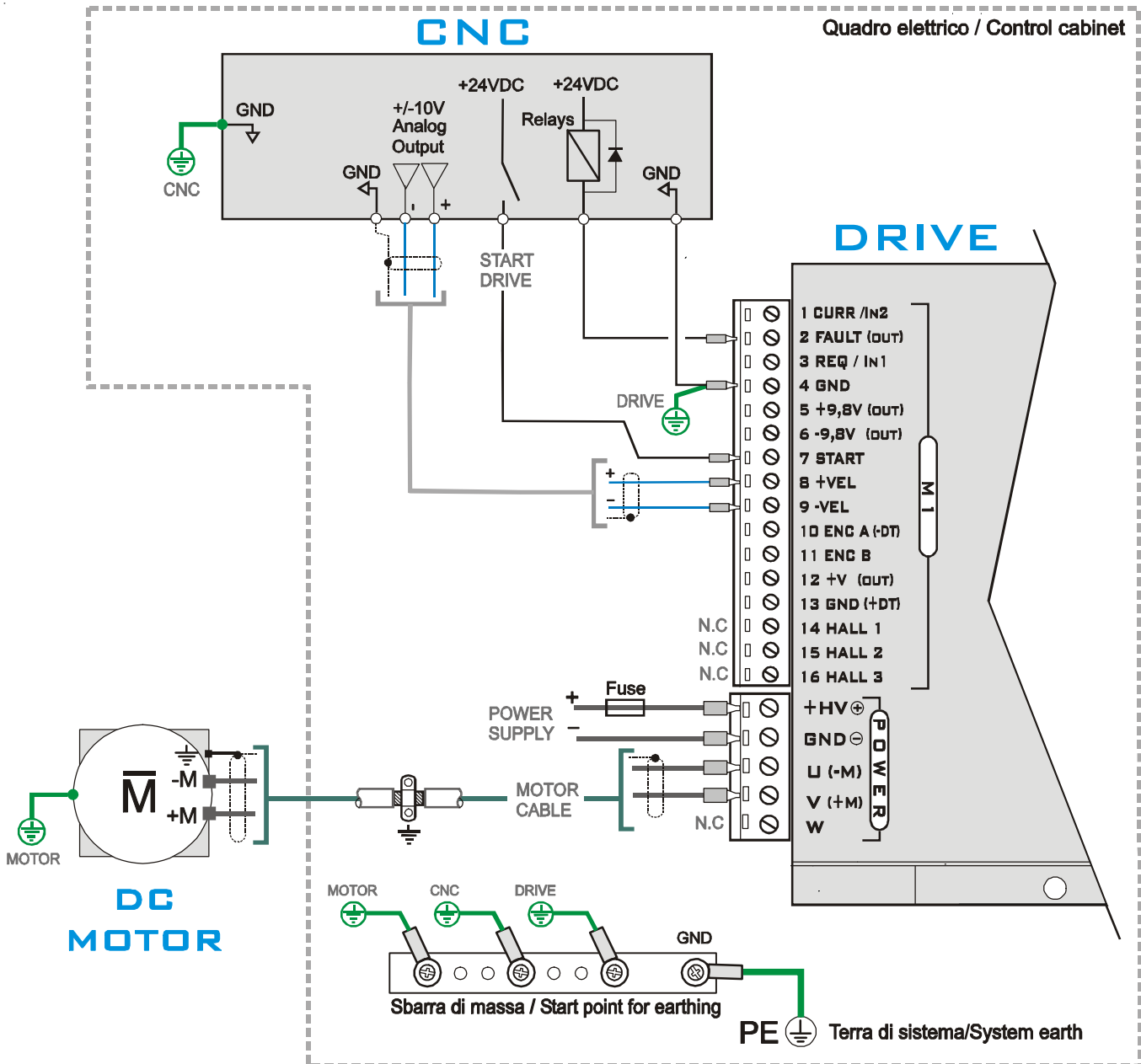

The following diagram shows an typical application utilizing a Drive with Brush motor. The speed loop velocity is by internal armature feedback.

The drive is made by factory in the BRUSHLESS MODE. For set in the **D.C mode**, closing the solder bridge S1.

Note: In the configuration for driving DC Brush motor, the terminals 14,15 and 16 should not be connected (NC)

Setting for Brush dc motor with armature

In this configuration, the drive must set with the following solder bridges and below internal setting:

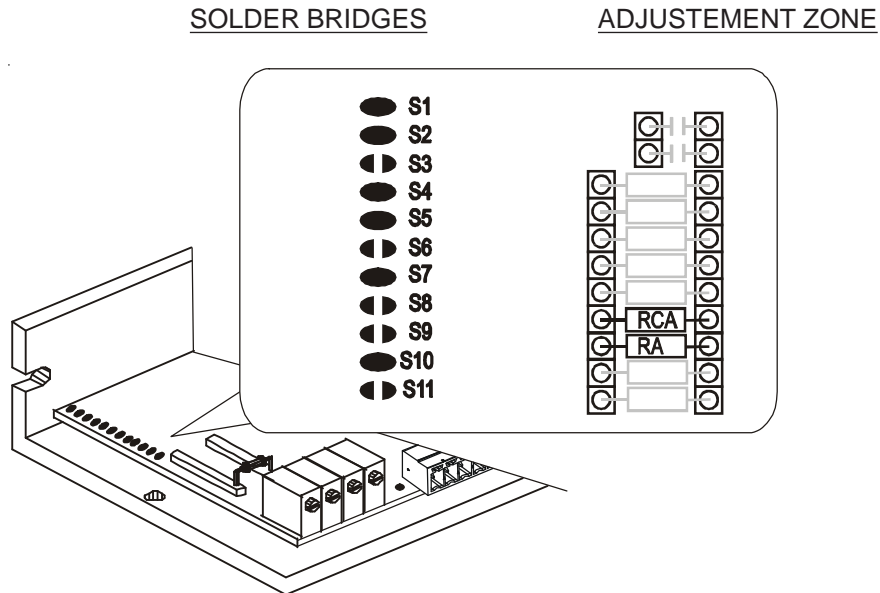

- Solder Bridges set for:
- Dc motor
 - Armature feedback
 - Ramp time disabled
 - Standard Dynamic constant

For the correct value of RA and RCA resistor (speed adjustment range) in armature feedback see chapter 3.2

Note: On the adjustment zone are not considered here the other components used to determine other calibrations "for example. Calibration current rating etc."

2.8 Brush dc motor with tachogenerator

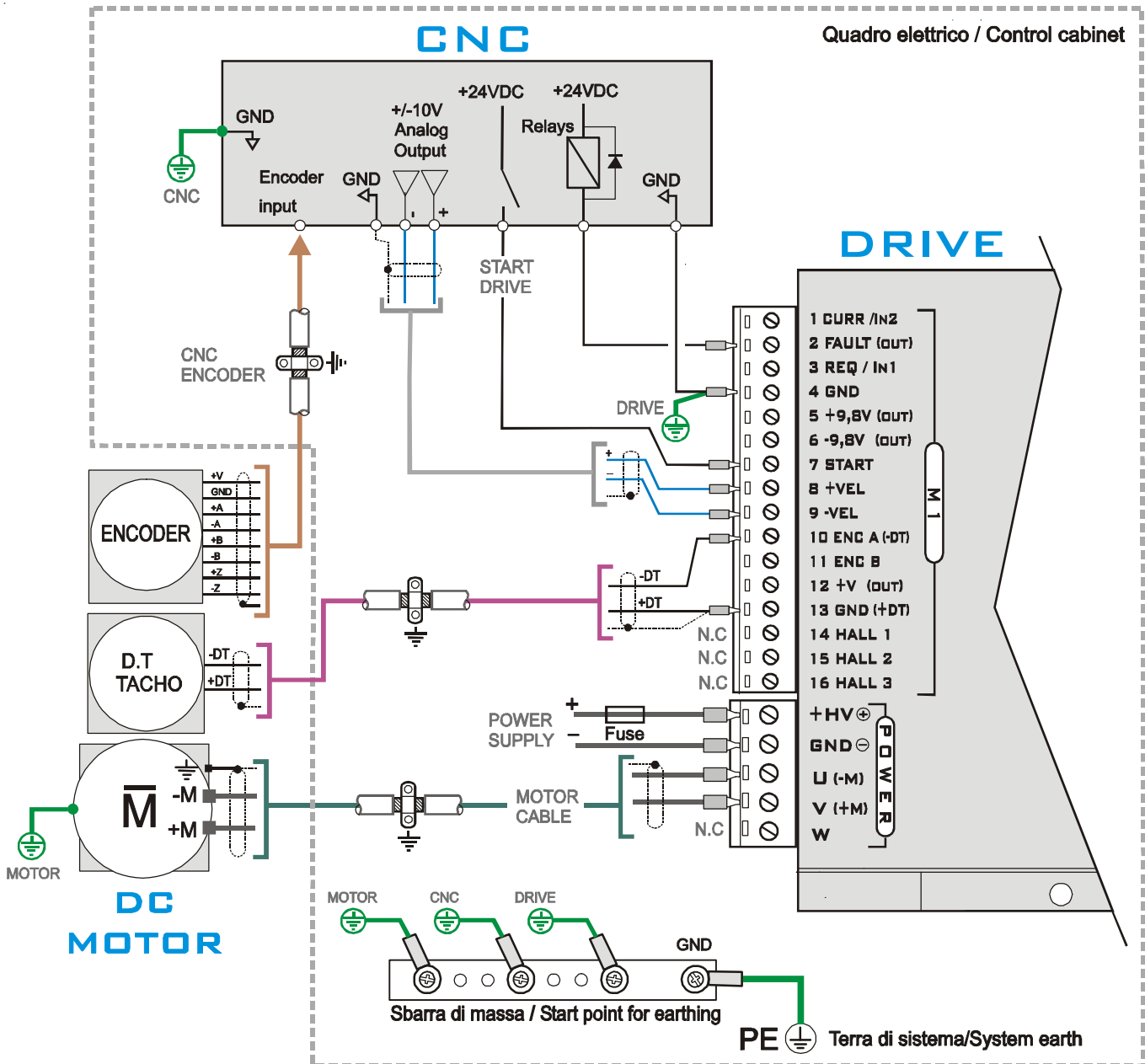

The following diagram shows an typical application utilizing a Drive with Brush motor. The speed loop velocity is by tachogenerator feedback.

The drive is made by factory in the BRUSHLESS MODE. For set in the **D.C mode**, closing the solder bridge S1.

Note: In the configuration for driving DC Brush motor, the terminals 14,15 and 16 should not be connected (NC)

Setting for Brush dc motor with tachogenerator

In this configuration, the drive must set with the following solder bridges and below internal setting:

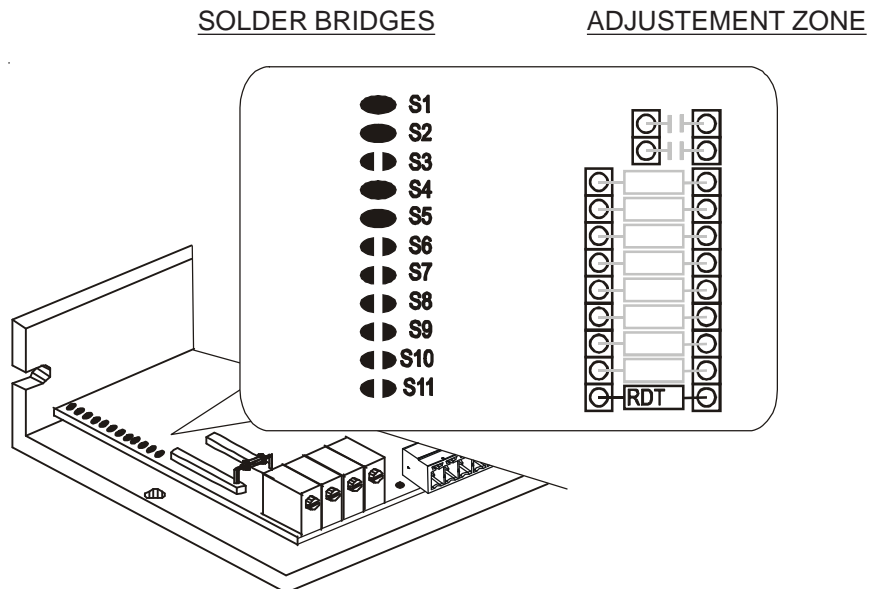

Solder Bridges set for:

- Dc motor
- Tachogenerator feedback
- Ramp time disabled
- Standard Dynamic constant

For the correct value of RDT resistor (speed adjustment range) in armature feedback see chapter 3.2

Note: On the adjustment zone are not considered here the other components used to determine other calibrations "for example. Calibration current rating etc."

2.9 Velocity inputs (+/-VEL)

Differential reference

(+/-VEL) This analog in differential mode has a 40Kohm of impedance input. The following diagram shows an application utilizing a differential reference from a C.N.C

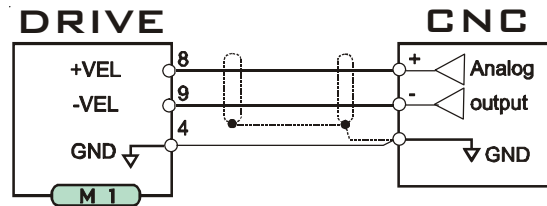

Common mode reference

This analog in common mode has a 20Kohm of impedance input. The following diagram shows an application using speed reference connections from C.N.C in the Common Mode.

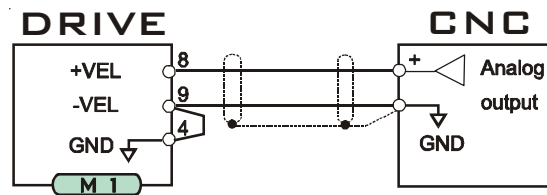

Speed reference from external potentiometer

The following figure shows an application with speed reference connections using an internal +/-10V power supply.

The speed potentiometer must have an included value between >5 and <10Kohm.

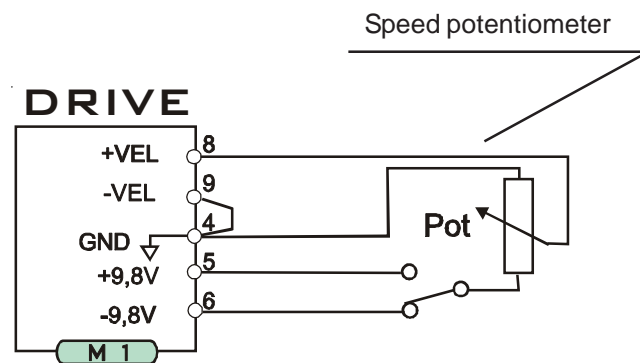

2.10 Current request (REQ)

With a voltage (example from a CNC output) you can command the drive in torque mode.

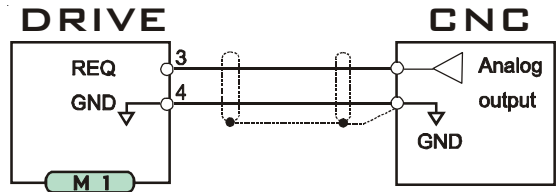

Applying a signal of +/-10V at TPRC, the Drive to supply positive or negative peak current. The formula to determine the value of Voltage to apply in TPRC in order to obtain requested current is the following:

$$V(\text{TPRC}) = 10 * \text{Request current} / \text{PKcurrent Drive}$$

Example: (Drive size 10/20A, request current 8A)

$$V(\text{TPRC}) = 10 * 8 / 20 = 4V$$

NOTE:

In current reference the loop of internal velocity automatically excludes itself .

Current output limitation

With an external potentiometer connected from GND and TPRC input, you have a limitation of output current (from zero to max. size) drive's.

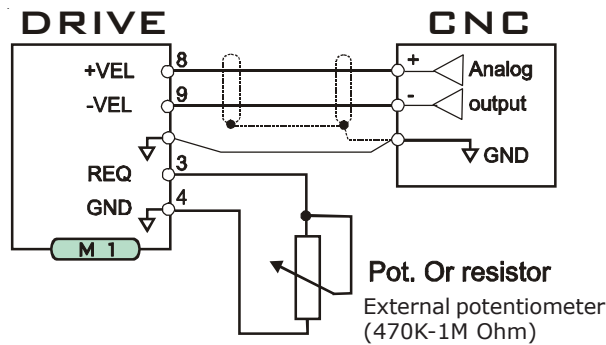

The speed ring remains active and uses the input reference signal. In this case the loop of internal velocity remains active.

2.11 Enabling with Start input

The standard drive is furnished in this configuration.

Start enable input has logic range: $\geq +9V$ to $+30Vdc$ (min/max)

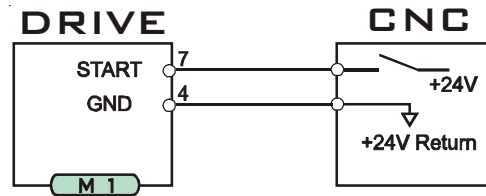

Unconnected Enable input = Drive Not Enabled

Enable Input $+24Vdc$ = Drive Enabled

Is possible enable the drive connected the START input with $+9.8V$ output "terminal 5"

2.12 Current monitor output

On this terminal is available analog output "current monitor of motor" with range $0V + /-8V$. The value of $8V$ is the maximum current supplied by the drive. For example, if we have a size $7/14A$, $8V$ corresponds at $14A$ circulating on the motor.

The signal can be positive or negative depending on the direction of rotation of the motor.

Output Impedance is $10Kohm$. Consider the internal impedance in the case are linked external resistive divider.

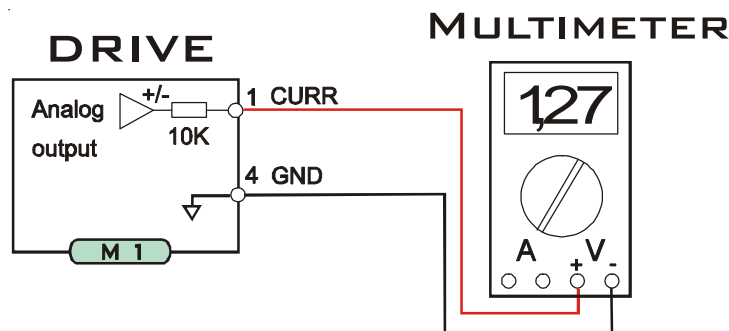

Note:

Standard product is set to the signal CURR on terminal 1 (reading of the current circulating on the motor) and the REQ input at terminal 3.

If these signals are not used, you can use these terminals for two other control functions named IN1 and IN2.

Through the inputs IN1 and IN2 (when set) you can limit the motor torque in the two respective directions of rotation of the motor (CW and CCW). Can therefore be used as limits Overtravel left and right.

Ask how to set these inputs in the factory.

3.1 Adjustment with encoder feedback

For this adjustment both Hall and Encoder signals are required from the **Brushless motor** as shown in diagram on Chapter 2.3 , 2.4 and 2.5

For **Brush dc motor** only Encoder is required as shown in Connections on Chapter 2.6

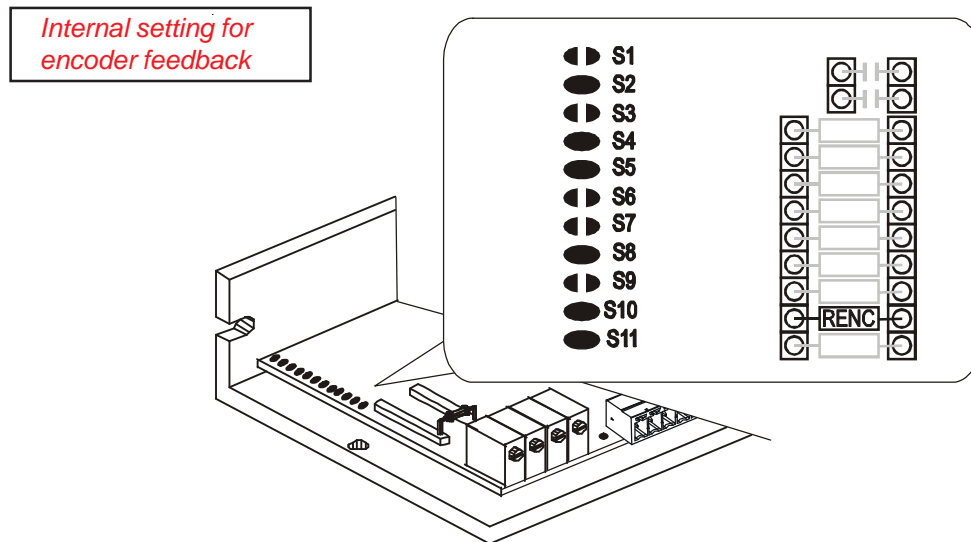

RENC resistor calculations

The drive is standard set with solder bridge S8 closed and the resistance calibration speed RENC already mounted on board "27Kohm" (Calibration for speed = 3000rpm encoder with 10V reference and 500PPR line-count resolution encoder.)

For change this resistance open the drive and calculation the following formula:

$$\text{RENC} = 681 * 1000 / \text{Fenc}$$

The resistor RENC determine what is the max. speed of the motor at 10V of reference.

Where: $\text{Fenc} = \text{PPR} * \text{rpm} / 60$

Example: N° encoder (PPR) = 500
Motor max. speed 4000 rpm

$$\text{Fenc} = 500 * 4000 / 60 = 33.333$$

$$\text{RENC} = 681 * 1000 / 33.333 = 20,4 \text{ kohm}$$

The result of RENC resistance is 20 or 22 Kohm. Prefer resistance with 1% tolerance.

Once the resistor RENC is inserted, proceed with final speed adjustment.

Operate using trimmer SPEED on the front of the drive. With Clockwise Rotation the *speed increases*.

With Counter Clockwise Rotation the *speed decreases*. The Range of regulation is about +/- 20%.

3.2 Armature feedback

For this adjustment Hall effect signals are required from the **Brushless motor** as shown in Connections on Chapter 2.3, 2.4, 2.5. For **Brush dc** motor, only +M and -M is required, as shown in Connections on Chapter 2.7

The voltage from the motor armature can be used as feedback when the motor doesn't have an Encoder. This function is enabled by closed Solder bridges below and inserting resistors **RA** and **RCA** on the personalization base. Armature feedback "PWM" gives good speed control along with acceptable torque at low velocity (>15 RPM). This method consider that such a solution is sensitive to Ri dropping inside the motor and can be compensated, however by inserting a compensation resistor **RCA**.

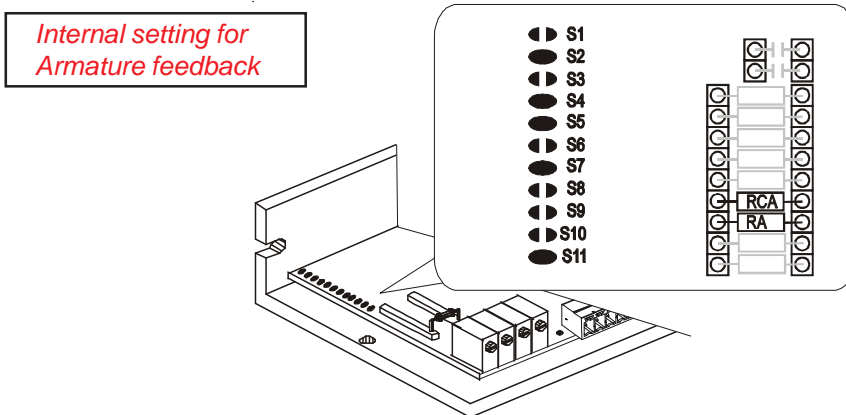

RA resistor calculations

Insert on base "RA" to adapt the system to use the motor voltage.

$$\text{Where: } V_{dc} = V_{rms} * 1,41$$

Table Vdc voltage

RA	33	27	22	18	15	12	10	8,2	6,8	5,6	4,7	3,3
Model 65	59	53	47	42	37	31,5	28	24,5	21,5	19	16	13,5
Model100	92	82	74	65	58	50	44	38	34	29	26	21,5

Value of RA in Kohm

EXAMPLE 1): **Brushless motor** with $K_e = 10V/Krpm$ (Vdc) — Voltage output drive
 Nominal speed $N^\circ = 3000rpm$
 Result: $V_{dc} = 10 * 3000 / 1000 = 30V$
 Drive model 60

EXAMPLE 2): **Brush DC motor** with $K_e = 26V/Krpm$ (Vdc)
 Nominal speed $N^\circ = 2000rpm$
 Result: $V_{dc} = 26 * 2000 / 1000 = 52V$
 Drive model 60

For the Example 1) result $V_{dc} = 30V$. The table shows a resistor with a value of 12Kohm.
 For the Example 2) result $V_{dc} = 52V$. The table shows a resistor with a value of 27Kohm.

Once the resistor **RA** is inserted, proceed with final speed adjustment.
 Operate using trimmer VEL on the front of the drive. With Clockwise Rotation the speed increases.
 With Counter Clockwise Rotation the speed decreases
 The Range of regulation is about +/- 20%.

RCA resistor calculations

Insert an RCA resistor on the header (ajustement zone) to compensate for voltage loss due to the motor resistance reducing the loss of RPM.

The formula is as follows:

$$\text{RCA (Kohm)} = \frac{0,49 * 1000 * V_{\text{mot}}}{V_{\text{ref}} * I_{\text{pk}} * R_i}$$

Where:

V= Nominal voltage of the motor

Ri=Max. cold motor resistance.

Ipk =Peak drive current.

Vref= max. applied reference voltage in VEL

Example: Drive 10/20A, Ri=0,9ohm, Vmot=24V, Reference=10V

Calculate:

$$\text{RCA (Kohm)} = \frac{0,49 * 1000 * 24}{10 * 20 * 0,9} = 500\text{K}$$

If after insertion of the resistor the motor is unstable, increase the Resistance value of RCA.

3.3 Speed balance (offset)

The drive is provided with zero adjustment OFFSET with the encoder feedback.

Adjust where necessary with the offset trimmer, to correct any external offset system. (This compensates approximately +/- 200mV on the reference input +/-VEL). With the reference input to zero, turn the trimmer until you stop the MOTOR.

This adjustment works with any type of speed feedback adopted

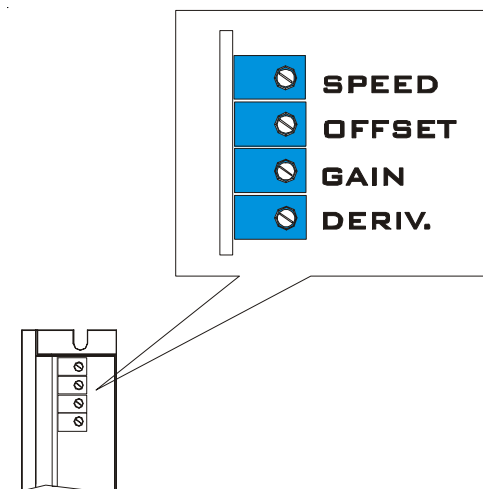

3.4 Tachogenerator feedback

The voltage from a tachogenerator can be used as feedback in the Speed One drive. This function is enabled through the following settings on the solder bridge, and insert the value of the resistor RDT.

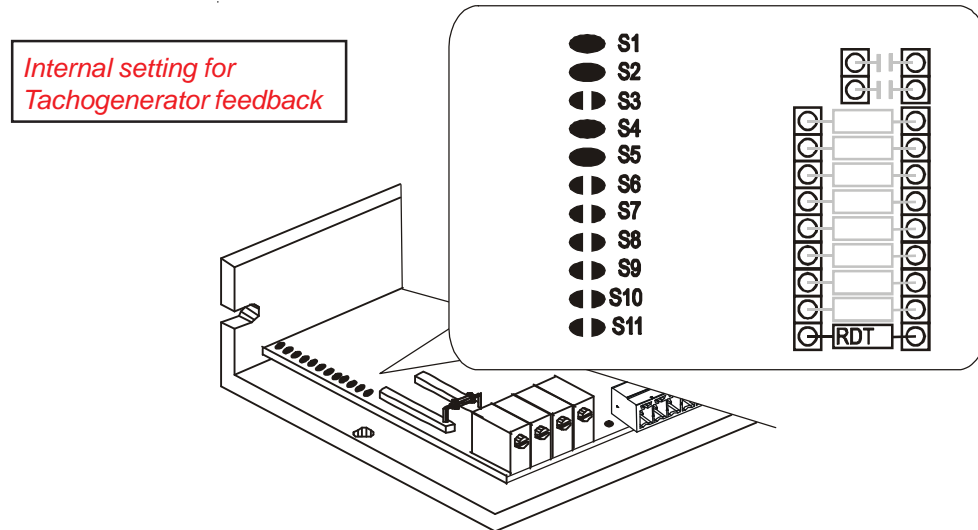

To calculate RDT resistor, please use the following formula:

$$\text{RDT (Kohm)} = \frac{\text{Kdt} * \text{N} * 9,7}{1000 * \text{Vref}} - 7,9$$

Example: Brush DC motor with the tachogenerator constant $\text{Kdt}=10\text{V/KRPM}$, max. speed 2500RPM at 10V of speed reference. The result is below:

$$\text{RDT (Kohm)} = \frac{10 * 2500 * 9,8}{1000 * 10} - 7,9 = 16.6 \text{ Kohm}$$

Insert the commercial value resistance 18 Kohm. Prefer resistance with 1% tolerance.

Note:

RDT is the value of resistor expressed in Kohm with a power rating of 1/8 or 1/4w.

Kdt is the tachogenerator constant V/KRPM

N is the max speed expressed in RPM.

Vref is the max voltage +/-VEL reference expressed in Volts.

Once the resistor **RDT** is inserted, proceed with final speed adjustment.

Operate using trimmer **SPEED** on the front of the drive. With Clockwise Rotation the speed increases.

With Counter Clockwise Rotation the speed decreases

The Range of regulation is about +/- 20%.

3.5 Current adjustment

RIN resistor (rated current adjustment)

Resistance RIN limits the value of the rated current supplied by the drive. Normally has the same value, of the stall current of DC motor. For the calculation see the following table:

Rin value	*	56	22	12	6,8	4,7	3,9	2,7	1,8	1,5	1
2/4	2	1,9	1,8	1,7	1,6	1,5	1,4	1,3	1,1	1	0,9
4/8	4	3,9	3,7	3,5	3,2	3	2,8	2,6	2,2	2,1	1,8
7/14	7	6,8	6,5	6	5,7	5,3	5	4,6	4	3,7	3,1
10/20	10	9,7	9,2	8,7	8,1	7,6	7,1	6,5	5,7	5,3	4,4

Note * = No resistor mounted.

RIP resistor (Peak current adjustment)

RIP resistance limits the maximum current supplied by the converter. For the calculation see the following table:

Rip value	*	470	390	220	150	120	100	82	68	56	47
2/4	4	3,7	3,5	3,2	3	2,8	2,6	2,5	2,4	2,1	2
4/8	8	7,4	7	6,48	6	5,6	5,3	5	4,8	4,2	4
7/14	14	13	12,2	11,3	10,5	9,9	9,3	8,7	8,4	7,5	7
10/20	20	18,5	17,5	16,2	15	14,1	13,2	12,5	12	10,7	10

Note * = No resistor mounted.

3.6 Ramp time adjustment

The product is standard setting with this feature is not enabled (Section S3 open)
 To enable the ramp acceleration close the solder bridge S3 and insert the RACC resistance.
 NOTE: The product comes standard with mounted 470ohm resistance value (0.8 sec ramp)

Ramp disabled (standard setting)

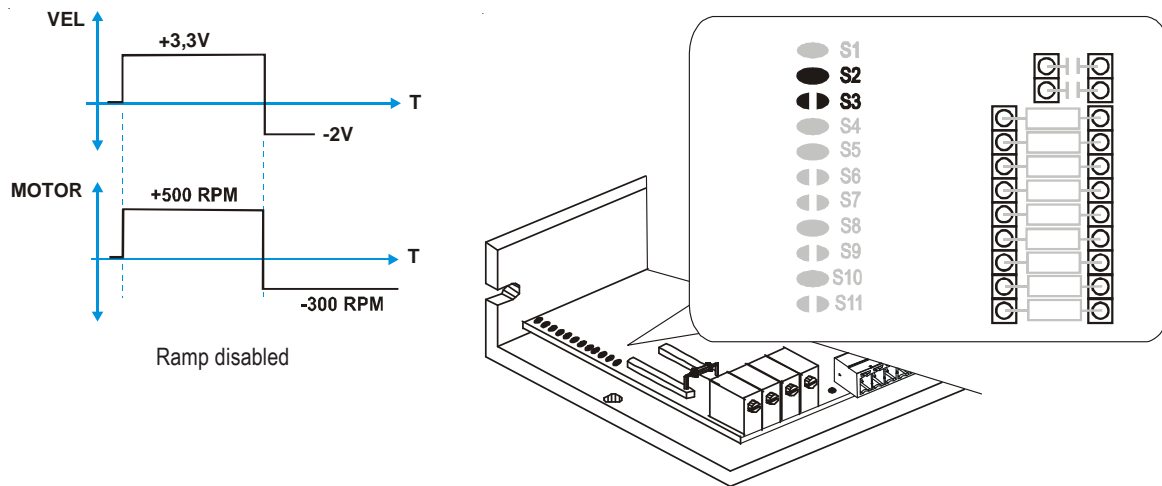

Ramp enabled

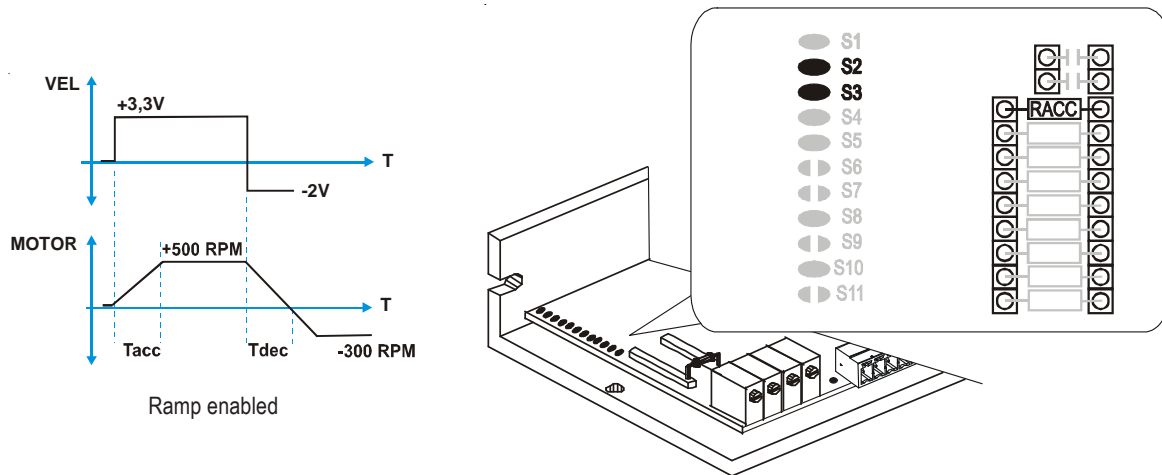

The time shown on the right are related to a change to step on the reference signal input +/-VEL of 10V. Example from 0 to 10V or 10 to 0V.

Table:

Resistance (ohm)	TIME (sec)
27 Ohm	15
68 Ohm	5
100 Ohm	3,16
470 Ohm	0,8
1K Ohm	0,32
1,5K Ohm	0,26
3,3K Ohm	0,16
10K Ohm	0,086

3.7 Dynamic adjustment

The multi-turn GAIN and DERIV trimmer allow to dynamically tune of the motor and its mechanics linked to it. These trimmers have full excursion from minimum to maximum, with 15 turns of rotation of the same.

The charts shown the track 1 "yellow" is the speed signal available in the point TEST. Track 2 blue highlights instead the current signal taken at terminal 1 (M1 signals connector pitch 3.81)

Signals are reported with a step voltage of the reference signal speed of about 2V.

These signals can be displayed by connecting the two probes of an oscilloscope at those points. The zero signal 0S (zero probes) can be connected by a wire to pin 4 (M1 signals connector pitch 3.81)

Velocity of the motor

Current of the motor

Behavior of the motor with both GAIN and DERIVATIVES trimmer to a minimum of function (trimmer totally rotated counterclockwise CCW). The speed signal is unstable, idem for the current signal of the motor. See chart at right

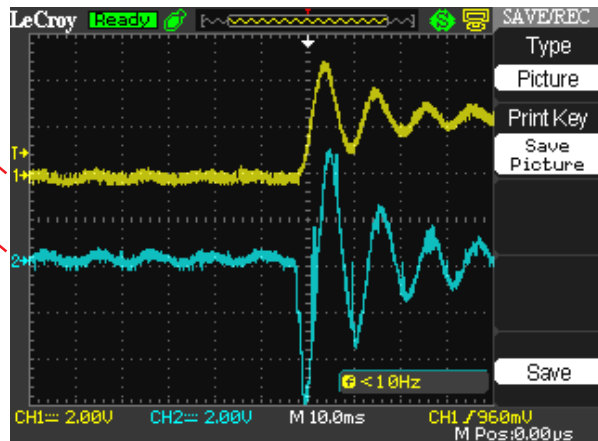

Turning clockwise CW the trimmer GAIN (4 / 5 turns) the dynamic behavior improves, not to exceed with this adjustment are otherwise the motor will be vibrating. See chart at right

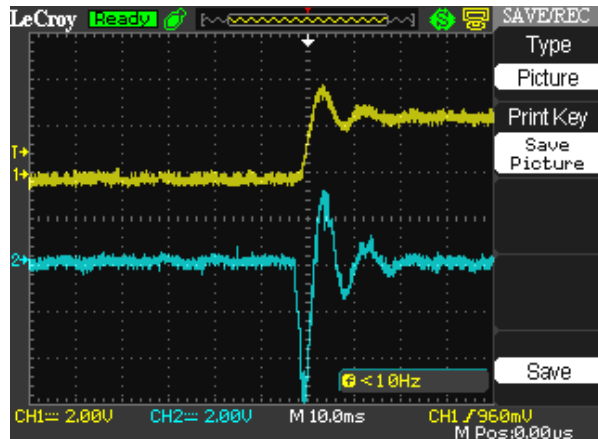

To further improve the behavior of the motor and mechanics related to it and the over all damping of the speed signal oscillation , act trimmer DERIV. turning it clockwise CW (4 / 5 turns). See chart at right

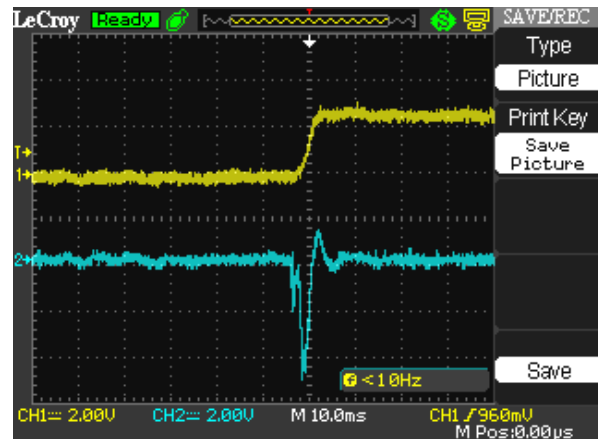

NOTE: The dynamic calibrations are performed using a reference speed (in +/-VEL) of about 1 or 2V. You can use the voltage output from the CNC control, paying attention to rule out the correction of space. Or use an external oscillator or a small battery 1.5 V

3.8 Troubleshooting

Possible reasons for the alarms

- **When power supply is on the green OK LED doesn't come on.** Check the voltage between +HV and -GND with a tester.
- **During deceleration of the motor, the LED green blinks.** Increase the capacity filter. (example from 10.000uF to 20.000uF)
- **LED lights red O.C.** Check the connections + M and -M can short circuit between these two wires, between one of these two wires and ground, or short circuit inside the motor.
- **LED lights red ixt.** Excessive mechanical load
- **LED lights red PTC.** Ambient temperature too high, or the converter does not have a minimum circulation of air cooling, ventilation or missing where expected from the size of the converter.
- **At Startup or Enabling the H.ALL Led comes on.** One or more missing Hall Signals. Missing power supply to Hall Cells.
- **With the green LED the motor will not start when you enable the drive with START**
Check for the enable signal START. Also verify the presence of the speed signal between the terminals + /-VEL
- **Motor goes out of control when enabled.**
 - Encoder signals incorrectly connected (ENC A and ENC B signals swapped, or encoder power supply missing, or tachogenerator signals swapped)